

WORKING CLEARANCE REQUIREMENTS FOR GAS SERVICE EQUIPMENT

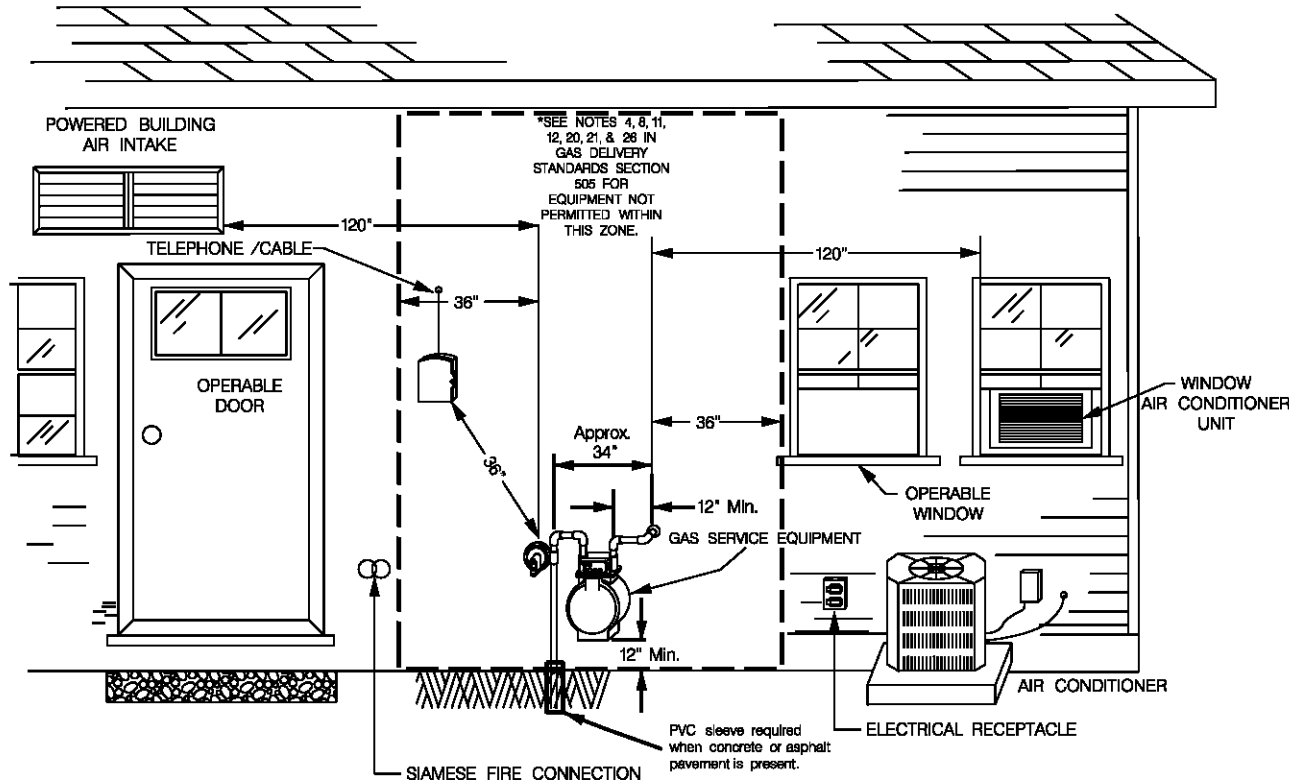

Edge of Building Clearances

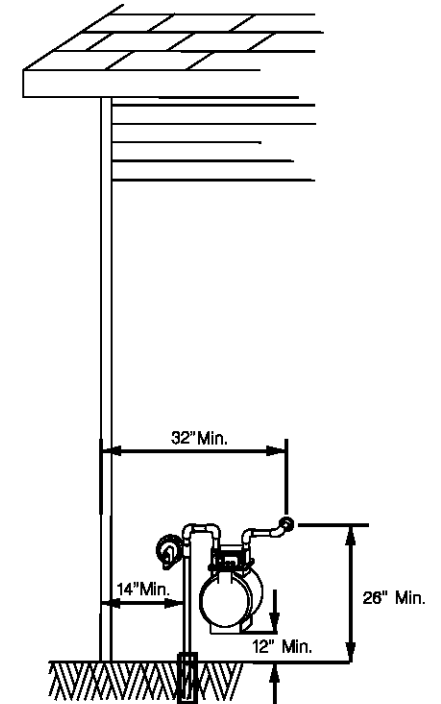

Note: Building must be free of drywall at time of visual inspection.

*Note: Other clearances on this drawing apply.

*Refer to latest version of "Gas Service Standards" for additional notes.

	Date	Approved
Issued	10/2/19	R.E.
Revised	12/6/19	

CPS ENERGY
CONSTRUCTION STANDARD
(GAS)

G-S-700-1-1