



Summary of Gas Service Standards
For
Engineers, Architects, Contractors and Developers

May 2011

**Copies of this manual are available online at
http://www.cpsenergy.com/Developers_Builders/New_Service/**

Copyright © 2010 CPS Energy. All rights reserved.

TABLE OF CONTENTS

100	Project Overview	6
101	Job Planning	6
102	Project Costs	6
103	Project Responsibilities	6
200	CPS Energy Delivery Pressures	7
201	Normal & Preferred Delivery Pressures	7
202	Elevated Delivery Pressures	7
203	Raising or Lowering Delivery Pressure	7
300	Gas Mains	9
301	Easement Requirements for Mains	9
302	Joint Utility Trenches for Mains	10
303	Burial Depth and Clearances for Mains	10
304	Mains Buried Beneath Concrete	10
305	Sleeves for Mains	11
306	Replacement or Relocation of Existing Mains	11
400	Gas Services	12
401	Gas Services and Risers	12
402	Gas Service Stubs	13
403	Services to Schools	14
404	Easement Requirements for a Service	14
404	Trenching a Service	14
405	Joint Utility Trenches for Services	15
406	Service Burial Depth and Clearance	15
407	Service Replacement or Relocation	15
408	Removing a Service	16
500	Meter Set Considerations	17
501	Diaphragm Meters	17
502	Rotary Meters	17
503	Meter Selection	19
504	Meter Manifolds	21
505	Meter Set Location, Requirements and Clearances	22
506	Meter Set Protection Requirements	24

507	Cabinet & Metering Room Requirements _____	28
508	Communications Enclosures _____	31
509	Service Regulator Vent Requirements _____	31
510	Electric Bonding & Grounding of CPS Energy Owned Gas Pipe _____	31
600	<i>Customer Requirements and Responsibilities</i> _____	33
601	Application for Service _____	33
602	Ownership and Responsibility _____	33
603	Yard Lines _____	34
604	Pressure Loss & Load Characteristics _____	34
605	Easements _____	35
606	Permits _____	35
607	Site Preparation _____	35
608	Protection _____	35
609	Required Information for Requesting Service _____	35
610	Request to Remove a Service _____	36
611	Qualified Agency _____	36
612	Master Metered Systems _____	36
700	<i>Technical References</i> _____	37
701	Quality of CPS Energy Natural Gas _____	37
702	Conversion Factors _____	38
703	Pressure Conversion Table _____	39
704	Pressure Conversion Formulae _____	40

CPS Energy Helpful Telephone Numbers

www.CPSEnergy.com

To obtain location of underground gas and electric lines:

Before digging, call the Texas One Call Center by dialing (800) 545-6005 (48 hours notice required.)

To report damage to underground CPS Energy gas and electric lines:

Telephone: **(210) 353-HELP (4357)**

Toll Free: **(800) 870-1006**

TDD for Hearing-Impaired Customers **(210) 353-4600**

To report CPS Energy gas or electric trouble (all hours):

Telephone: **(210) 353-HELP (4357)**

Toll Free: **(800) 870-1006**

TDD for Hearing-Impaired Customers **(210) 353-4600**

When planning new construction, service and meter installations:

Telephone: **(210) 353-3333 or (210) 353-4639**

TDD for Hearing-Impaired Customers **(210) 353-2224**

To apply for a gas or electric meter and service:

Telephone: **(210) 353-3333 or (210) 353-4639**

A copy of this manual is available online at www.cpsenergy.com

One Call System (Underground Utilities Locator Service)

<http://www.texasonecall.com>

The Damage Prevention Bill for Texas (House Bill 2295) took effect October 1998, and is known as Utilities Code Title 5, Chapter 251. This law requires most facility owners to join a notification (or one call) center and requires most excavators to call 48 hours prior to digging. It also requires any notification or one call center operating in Texas to share messages they receive between the notification centers. This provision is to ensure that excavators need only make one call to notify most buried facility owners. The Dig Safely program was introduced nationwide in June 1999. Its purpose is to help protect underground utility lines from damage by excavators, and protect excavators from the effects of damage to underground lines. The Dig Safely program stresses that safe excavation is a four-step process:

1. Call before you dig. The One Call Center is an important part of the damage prevention process. The One Call Center operates a toll free number 24 hours per day for excavators to use. The DIG TESS One Call Center is available by calling (800) DIG TESS (800-344-8377) or call the **One Call System of Texas at (800) 545-6005**. CPS does not provide direct access to CPS' utility locating service. All natural gas or underground electric facility locating is coordinated through "One Call."
2. Wait the required amount of time. Texas law requires at least two working days notice before beginning excavation. This means a homeowner who is putting in a fence on Saturday must call no later than Wednesday.
3. Respect the marks. If a potential problem exists, the utilities or their agents will mark the approximate location of buried facilities, using paint, flags, stakes, or a combination. During the project, it is the excavator's responsibility to make sure the utility marks remain visible. If they are obliterated, the excavator must call for a re-mark.
4. Dig Safely. Once the work begins, it is up to the excavator to use safe, accepted digging practices.

Regardless of how careful the preparation has been, the excavation work must be performed in a prudent and careful manner. The Dig Safely campaign is the result of cooperation between the National Transportation Safety Board, Office of Pipeline Safety, and representatives from the industries that own and operate underground facilities. These industries include communications (local, long distance, and CATV), electric power and gas utilities, pipelines, municipalities, and local, state, and federal regulatory agencies.

External Resources:

- Title 49, Code of Federal Regulations (CFR) (most recent & accepted revision);
- Title 16, Texas Administrative Code (TAC) (most recent & accepted revision);
- National Fuel Gas Code (NFPA 54 or ANSI Z223.1, most recent & accepted revision; see National Fuel Gas Code at <http://www.nfpa.org>);
- International Fuel Gas Code (IFGC), latest Edition (currently the City of San Antonio and area municipalities have incorporated this resource for code requirements).

100 Project Overview

101 Job Planning

To verify availability and plan natural gas jobs:

1. **For new Construction, maximum consumption < 800 CFH**, call 210-353-4639, or e-mail NSDInformationDevelopmentTeam@CPSEnergy.com. However, for services South of IH10 - US90 and West of IH 37, forward an e-mail to NSDInformationDevelopmentTeamSWA@cpsenergy.com.
2. **For new Construction, maximum consumption > 800 CFH** call (210) 353-2539.
3. **For remodeling, increasing or decreasing gas pressure, adding or reducing load, moving or removing a service or initiating or turning off gas flow, or abandoning a service** call CPS Energy at (210) 353-3333 after receiving all required releases from any authority having jurisdiction.
4. CPS Energy requires the Customer's name, contact information, service location, a site plan showing the desired route of gas service, a "need-by" date and the type and operating schedule of facilities to be served (including the rated CFH or MBTU consumption capacity of all proposed gas devices).

102 Project Costs

1. CPS Energy will provide an estimate of costs and possible load credits to provide natural gas service. The Customer is responsible for the final actual cost. Estimated costs must be paid in advance before work will commence.

103 Project Responsibilities

1. CPS Energy is not liable or responsible for gas piping and appliances located downstream of the gas meter.
2. CPS Energy may refuse to supply gas to piping or appliances installed or operated in an unsafe manner.

200 CPS Energy Delivery Pressures

201 Normal & Preferred Delivery Pressures

1. **Threaded or Welded Rigid Steel or Polyethylene Piping**
Four (4) ounces or seven (7) inches of water column (7" WC) is the **standard** delivery pressure for ALL residential and most commercial Customers.
2. **Flexible Corrugated Stainless Steel Piping (CSST)**
Two (2) psig is the standard delivery pressure for all residential and light commercial Customers utilizing CSST piping (requires Customer installed downstream regulation).
3. **Standard Pressure for Commercial Manifolds**
The standard delivery pressure for commercial multi-meter manifolds is 2 psi (4 oz was standard prior to January 2010).

202 Elevated Delivery Pressures

1. **One (1) or Three (3) psig [Elevated Pressure]**
Available to commercial and industrial Customers on a case by case basis in areas served by Distribution Pressure (DP) Mains.
2. **Five (5) psig [Elevated Pressure]**
Available to industrial or commercial Customers on a case by case basis in areas served by Supply Pressure Distribution (SPD) Mains.
3. **Greater than five (5) psig, or, Line (Main) "Elevated Pressure"**
Available to industrial Customers in select areas and evaluated on a case by case basis by CPS Energy.
4. **Additional Requirements for Elevated Delivery Pressure**
Regulators that satisfy code requirements downstream of the CPS Energy gas meter will be Customer designed, owned, maintained and installed at Customer cost. CPS Energy will not provide service if code required regulation is absent.

Note: For Customers served through an industrial meter set (*usually an elevated delivery pressure and load of 7,000 scfh or greater*) that incorporates a load regulator *and* a monitor regulator, their installed equipment must be capable of handling the "lock up" pressure of the industrial set. CPS Energy will install a monitor regulator at 150% of the Customer's delivery pressure for delivery pressures less than one (1.0) psig and 125% for delivery pressures over one (1.0) psig. Example: if the Customer is receives gas through an industrial meter set at 3-psig, they must be capable of handling a 3 ¾-psig maximum delivery pressure.

203 Raising or Lowering Delivery Pressure

To raise the delivery pressure,

1. Contact a licensed plumbing contractor or engineering firm to determine if undersized piping will be adequate at higher pressure.
2. Contact CPS Energy as indicated in Section 101 to determine availability.

3. Pressure test and provide CPS Energy documentation that the house pipe will accommodate higher pressure per code requirements. The International Fuel Gas Code (utilized by the City of San Antonio) will be used for determining pressure test requirements in unincorporated areas.

A 4 ounce delivery customer served from a multiple-meter manifold that requests an elevated pressure may receive such pressure if approved by CPS Energy. The facility owner must:

1. Provide written documentation stating that the tenant may receive the elevated pressure;
2. Accept responsibility to notify future tenants and/or a purchaser of the facility of the elevated pressure; and
3. Install regulators for existing Customers already served gas at lower pressure through the manifold.

To lower the delivery pressure,

1. Contact a licensed plumbing contractor or engineering firm to determine if existing piping will be adequate at lower pressure.
2. Contact CPS Energy as indicated in Section 101.
3. Be aware that CPS Energy will not provide a pressure less than 4 oz.

300 Gas Mains

301 Easement Requirements for Mains

1. Gas Mains require easements of 14' (10' min). Less than 14' requires CPS Energy approval. Shared facility easements may require greater width.
2. All easements must be provided without charge to CPS Energy and be cleared and maintained to allow unencumbered use by CPS Energy.
3. Planting trees or shrubs, building fences, erecting poles or any permanent structure on an Easement is prohibited. In the event an obstruction must be removed by CPS Energy, the Customer is responsible for the cost.
4. Once granted, rights of way and easements will continue in effect even if ownership of the property changes.

Individual Gas Mains

1. Individual gas mains will be installed on the north and east sides of streets, alleys, easements or rights-of-way when possible and practical.
2. In established areas, the distance of the gas main from the property line will depend upon the position of the existing main, width of the parkway, width of the paving, and any unusual conditions such as other utilities or obstructions. In new subdivisions, this distance should be 6 feet unless preempted by another utility.
3. The main should be placed outside the paving (existing and proposed) if possible and practical.

Residential Distribution Sub-Division Mains

Front Lot Construction is the CPS Energy standard method for installing joint gas and electric facilities. Front Lot Construction requires the following.

1. Lots served must have a seven (7) foot Gas, Electric, Telephone and Cable TV easement along frontage with grade level at transformer location to be the same as parkway grade level.
2. CPS Energy will perform trenching and backfilling. With permission, the Customer may be permitted at their expense to trench and backfill within the exact specifications provided by CPS Energy. CPS Energy will assume ownership following inspection and acceptance.
3. Boring is permissible if clearance is questionable. The minimum bore must be 2" larger than the gas pipe and greater for significant pipe deflections. For polyethylene pipe a fusible link/approved device ≥ 2 ft long and 1 pipe size smaller than the installed pipe shall be used between the pull head and installed pipe. Once pulled, the fusible link and leading edge of installed plastic pipe or the steel pipe coating will be inspected for significant gouges/scrapes and, if present, the pipe will be removed and replaced.
4. A contractor installing gas pipe must be certified by CPS Energy.
5. Coordination of joint trench will be performed during a Pre-Design meeting scheduled by the Developer or Developer's Engineer.

6. Gas & Electric trench will be a standard of forty-eight (48) inches in depth. Installation of participant services will be installed to CPS Energy guidelines.
7. CPS Energy will credit a Developer half the trench costs if CPS Energy gas infrastructure is installed. The credit will be determined by CPS Energy.

Further design guidelines and information regarding Front Lot Construction are largely dictated by requirements associated with the Electric Distribution system. To that end, it is recommended that the Customer/Developer contact CPS Energy Subdivision Planning for further information.

302 Joint Utility Trenches for Mains

Due to safety considerations, CPS Energy will not share a (main) joint trench with competing utility companies, but when an underground electric 3-phase duct bank or service route is the same as for the gas main, a joint trench may be utilized by CPS Energy and may with CPS Energy approval include telephone and cable television facilities.

Six inches minimum clearance between the gas pipe and the electric conduit (primary or secondary) is required in gas main trenches.

303 Burial Depth and Clearances for Mains

Cover and clearances for gas mains must be \geq those listed in Table 1.0 unless approved by CPS Energy or required by Governmental Authority.

Table 1.0 – Burial Depth (Cover) Requirements and Clearances for Mains (burial depth from finished grade)

	Clearances ¹	Subdivision Cover	ROW Cover
Distribution Gas Mains	12" minimum, 6" joint trench	24" minimum	36" for Rd Crossings
Transmission Gas Mains	12" minimum	36" minimum	36"-48"
Gas Lines in TxDOT ROW		48"-60"	48"-60"

¹ A Clearance exception may exist in joint trench applications (See Section 302)

304 Mains Buried Beneath Concrete

Gas mains are not allowed under a permanent concrete structure or slab. Gas mains are permissible in easements beneath concrete parking lots, sidewalks and driveways or driveway approaches. The Customer is responsible for repair costs to the concrete for CPS Energy maintenance/installation/repair work performed when the main is beneath or in close proximity to the concrete.

Gas mains are strongly discouraged beneath or in close proximity to concrete located within rights-of-way, where the Customer is responsible for all CPS Energy costs as a result of the installed concrete. The Customer must notify CPS Energy if such paving activity is planned.

305 Sleeves for Mains

Pipe sleeves for gas pipe may be installed to facilitate construction schedules.

1. Steel gas pipe cannot be sleeved.
2. Polyethylene (PE) pipe can be sleeved if sleeve ends extend beyond the area of concern (curb, concrete, landscaping, etc.).
3. Sleeves cannot be used to turn 90 degrees. An expansion joint (block out) specified by CPS Energy can be installed to turn and attach the pipe.
4. Depth and clearance requirements apply to sleeves.
5. Sleeves must be \geq schedule 40 PVC and \geq 2 inches larger than the gas pipe.
6. Allow safe, unobstructed sleeve end access for CPS Energy personnel and equipment. 90° ells and a vertical capped pipe on sleeve ends are recommended for locating sleeves and preventing sleeve contamination.

306 Replacement or Relocation of Existing Mains

The Customer should discuss specific scenarios with a CPS Energy representative well in advance of any planned activities.

Gas Mains that require replacement due to deterioration or obsolescence will be installed by CPS Energy at no cost to the Customer.

The Customer will pay the costs for mains that must be moved or modified for a Customer project. However, CPS Energy will contribute to the Customer costs in accordance with the CPS Energy Line Extension Policy if the project increases gas consumption (load credits).

400 Gas Services

401 Gas Services and Risers

1. Gas services should be installed along the shortest practical, available and accessible route that is not subject to undue stresses, hazardous conditions or obstructions. Obstructions may require removal at Customer expense.
2. Gas Services should not be installed where erosion, pooling of water, blasting operations, excessive soil subsidence or tunneling operations occur.
3. A gas service should be installed parallel to the lot line and at 90° to the main. If a lot line is not perpendicular to the main, a bend at the property line is allowed to keep the lot line and service parallel. If a bend is not practical, the entire service may be run parallel to the lot line (see Illustrations on the following page).
4. When offsets are necessary, they should be made at right angles.
5. When making a stub extension, any necessary offsets should be made inside the property line unless a lot line would be crossed, then the offset would be made on the street side of the property line.
6. A new gas service cannot cross a 3rd party's property or connect to the gas service of the 3rd party without CPS Energy approval. A written acceptance agreement and easement must also be obtained from the 3rd party.
7. Gas services will not be connected within 10' of the end of a main if the main could be extended in the future. If not extendable, within 5' is permissible.
8. The Customer may be required to dig the service trench if the slope along the service route is greater than 33% of grade (3 horizontal to 1 vertical ratio).
9. Gas Services WILL NOT be installed under or through concrete slabs, buildings, roofed passageways or enclosed or limiting structures.
10. Service pipe or stubs for residential lots may be installed in dirt or within a 3" to 4" schedule 40 pvc pipe sleeve or conduit.
11. Service pipe or stubs do not require encasement within a conduit or pipe sleeve when crossing beneath streets or sidewalks.
12. Pipe sleeves or conduits may be used for installing up to 2 stubs or services.
13. A pipe sleeve or conduit must extend beyond the pavement, concrete or curb.
14. Gas services should not extend more than 5' beyond the building wall nearest the gas main. If the distance is greater, the service line should be installed parallel to the building but at least 5 feet from the wall.
15. A Gas Service riser MUST be located ≥ 12 inches from the final building wall.
16. Installing a riser requires a 3' x 5' clear area (exposed dirt). The 5' dimension must be in line with the route of the service pipe.
17. A concrete apron or sidewalk poured after a riser is installed requires a schedule 40 PVC collar around the riser that is 2" or larger than the riser OD.

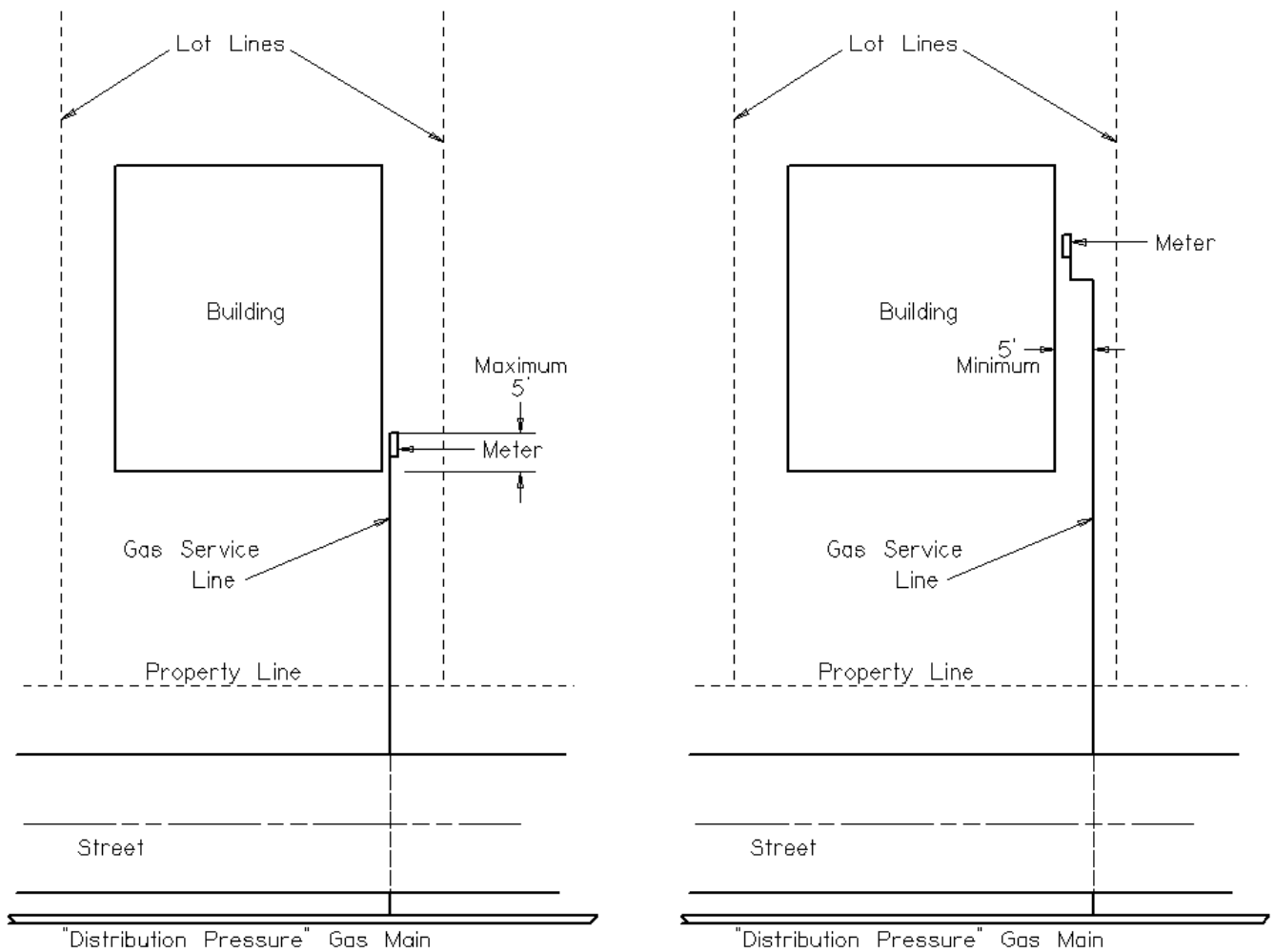

Examples of Typical and Alternate Gas Service Installations

402 Gas Service Stubs

1. Stubs for future Customers may be installed when installing gas main.
2. Stubs will be sized for anticipated usage and should terminate 1 foot inside the property line.
3. Service stubs may cross beneath streets and sidewalks and can be installed to serve residential lots on either side of a street.
4. One service stub may be used to serve 2 adjacent customers connected to Distribution Pressure mains (< 10 psi) and are called "Longhorns". The "Longhorn" is considered a service, not a main.
5. Adjacent lots served by an SPD main (pressure > 10 psi) require two stubs with EFV's. The stubs may occupy the same trench beneath streets, sidewalks and along public rights-of-way.

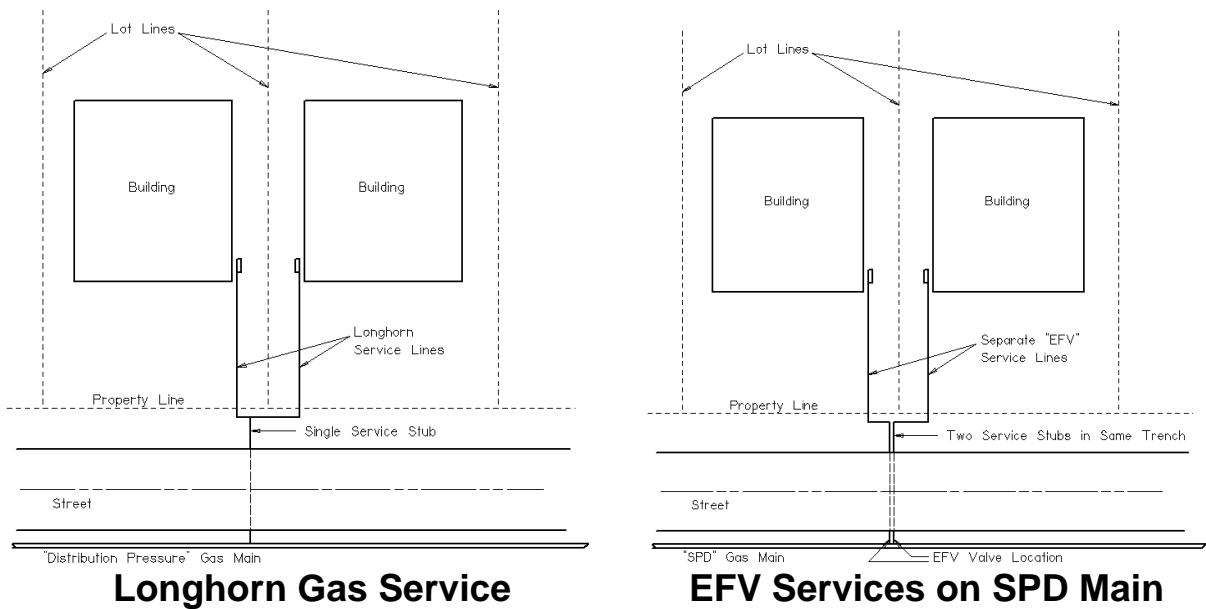

403 Services to Schools

Services to schools will be installed in the same manner as other commercial service installations, but it is recommended that a Customer install a valve immediately downstream of the meter set to protect the meter and regulator during a pressure test of School facilities subject to State mandated periodic testing. Damages to meters/regulators caused by School pressure tests are the School's responsibility. For test pressures and requirements of School pressure testing, consider reviewing the articles located on the CPS Energy website at http://www.cpsenergy.com/Commercial/Information_Library/School_Pipe_Testing/index.asp.

404 Easement Requirements for a Service

1. Residential and commercial gas services do not require easements (as opposed to *commercial* Electric services). However, no building, structure, slab, pool or other fixed equipment or facilities will be constructed over a gas service without CPS Energy consent.
2. Planting shrubs, hedges, flowers or anything other than grass over a service should be avoided. Planting trees over a service is *strictly prohibited*.
3. CPS Energy has the right to recover all costs associated with relocating a service if the Customer has impaired the service line or access to same.

404 Trenching a Service

CPS Energy usually installs services, but a Customer may be permitted to trench and backfill a service to CPS Energy specifications at Customer expense. Only after inspection and acceptance will CPS Energy take ownership of the service.

405 Joint Utility Trenches for Services

Due to safety considerations, CPS Energy will not share a (service) joint trench with other utility companies or private entities/landowners, but when an underground electric 3-phase duct bank or service route is the same as for the gas service or main, a joint trench may be utilized by CPS Energy and may with CPS Energy approval include telephone and cable television facilities.

Where gas, electric, telecommunications, water lines (including irrigation lines), sewer lines or other piping entering a facility are installed in close proximity, a minimum horizontal separation of twelve (12) inches from the gas service/riser must be maintained where the facilities transition from below ground. An exception will be made for the separation between CPS Energy secondary, electric service conduit and gas-service piping, which may be reduced to six (6) inches. Clearances between other facilities can only be reduced by mutual agreement with CPS Energy.

No telecommunication cables, enclosures, wires, conduits or other equipment may be installed within twelve (12) inches above or alongside a gas meter/service/riser or anywhere behind said facilities on a perimeter building wall.

406 Service Burial Depth and Clearance

Cover and clearances for gas services must be \geq those listed in Table 2.0 unless approved by CPS Energy or required by Governmental Authority.

**Table 2.0 – Burial Depth Requirements and Clearances for Service Pipe
(burial depth from finished grade)**

(See Section 407 for joint electric/gas trench depth and cover)

	Clearances	Subdivisions	ROW
Service Line Installations through Private Property	12" minimum, 4" joint trench	12" minimum	
Service Line Installations through Public Property	12" minimum, 4" joint trench	18" minimum	18" minimum

407 Service Replacement or Relocation

The Customer should discuss specific scenarios with a CPS Energy representative well in advance of any planned activities.

A gas service that requires replacement due to deterioration or obsolescence will be replaced by CPS Energy at no cost to the Customer.

The Customer will pay the costs for a service that must be moved or modified for a Customer project. However, CPS Energy will contribute to the Customer costs in accordance with the CPS Energy Line Extension Policy if the project increases gas consumption (load credits).

408 Removing a Service

CPS Energy reserves the right to remove a gas meter and all of its other assets to protect against fraud, theft, damage or destruction; or, if a Customer connects to another natural gas supplier or ceases to use any gas for 6 months.

CPS Energy will cap a service pipe at the property line or gas main, remove the meter facilities and either abandon in-place or remove the gas service pipe at no charge if a Customer requests removal of a gas service. Contact CPS Energy at (210) 353-3333 to request removal of a gas service.

500 Meter Set Considerations

501 Diaphragm Meters

Diaphragm meters are the most common type of gas meter installed by CPS Energy. They are well suited for a wide variety of applications in the CPS Energy service area and are used for non-constant loads, small and/or gas manifold installations. Diaphragm meters at CPS Energy can range anywhere from a residential size with 1 inch top connections capable of providing 175 scfh @ 7 inches water column to industrial sizes with 4 inch side connections providing 5,000 scfh @ 7 inches water column.

If greater flows are required, meters can be set in parallel (combined consumption) to accommodate Customer needs. In addition, meters are often set in combined consumption to allow two or more smaller meters to serve a facility rather than one very large one. However, combined consumption meter sets may require a larger overall footprint to install.

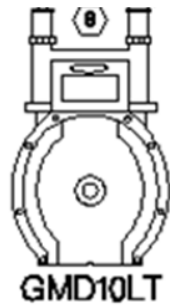

Though versatile, diaphragm meters are large in size. When space restrictions become a concern, rotary meters may be better suited to the application than a diaphragm meter.

Diaphragm Meter



502 Rotary Meters

Rotary meters are normally utilized for constant loads or high volume users (e.g. restaurants, laundry mats, manufacturing, etc.).

A rotary meter's accuracy cannot be modified or changed. Flow rates should not exceed the rated capacity of the meter, so the meter size should match the anticipated load as closely as possible to ensure accurate measurement. Proper sizing of meter capacity to load conditions will minimize under-registration due to low-flow slippage.

The rated capacity of a rotary meter does not vary with the specific gravity of the gas, and no correction factor is applied to the tabulated capacity values. Measurement by rotary meters can be advantageous by simplifying the measurement of gases that have variable specific gravity.

ROTARY SIZE	CAPACITY CFM	"A" INCHES
8C DRESSER	800	36
1.5 DRESSER	1500	45
3M DRESSER	3000	54
5M DRESSER	5000	60

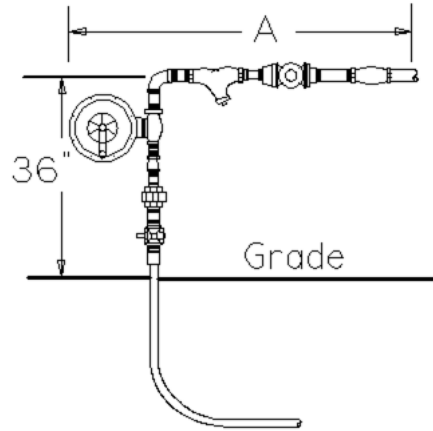

Shown below is a typical 16M Rotary Meter schematic employed by CPS Energy for large industrial type loads requiring a capacity of up to 16,000 cfh. A slightly smaller footprint would be utilized for a 7M Rotary (7,000 cfh rating) or an 11M Rotary (11,000 cfh rating). A concrete slab approximately 10ft x 14ft would be required if the installation is not installed on asphalt.

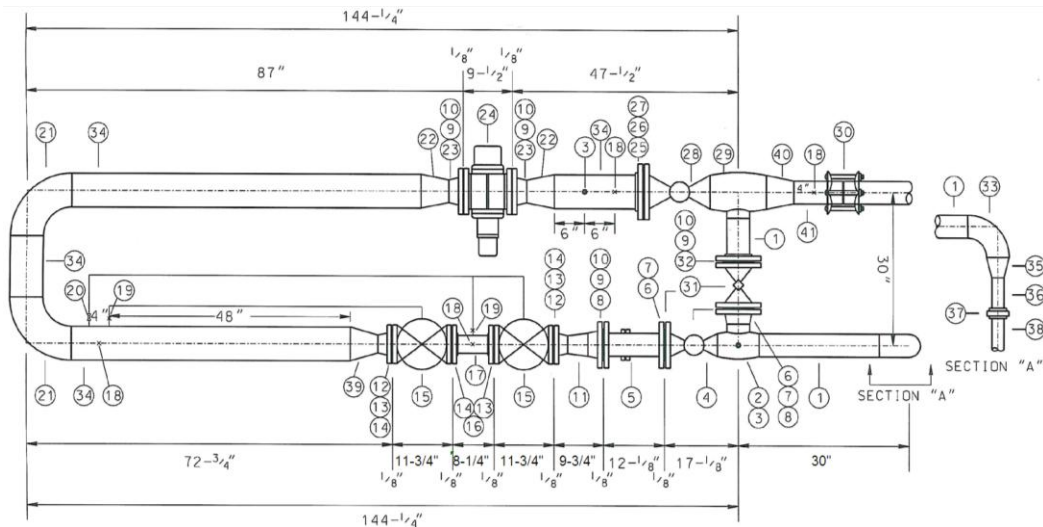

Diagram of typical 16M Rotary Industrial Meter Set

Volume Correctors and Pulse Metering

Volume correctors are used to collect consumption data, take into consideration temperature and pressure of a gas stream and “correct” the measurement reads for greater accuracy. CPS Energy installs volume correctors on a case-by-case basis. A Customer has the ability to download pulse values from a volume corrector and can review the consumption for energy auditing.

Pulse metering is similar to a volume corrector in that it incorporates a metering scheme that occurs when the meter generates pulses based upon flow to a recording device. The Customer can access the recording device to monitor usage and manage loads. However, a pulse metering device does not take temperature/pressure into consideration to “correct” the read.

CPS Energy will install volume correctors and pulse metering at prepaid Customer cost if a Customer requests them for energy management purposes. CPS Energy will bring the pulses from the device to a trough at or near the gas metering facilities where the Customer is responsible for completing the installation to access the information. This Customer owned and maintained installation would require the following:

- A nominal one (1) inch diameter conduit housing a direct, inward dialing telephone extension or standard voice grade analog telephone line terminating in the trough with a network interface device. The conduit and telephone cable will extend from the closest telephone location to the trough. The telephone extension or line cannot be shared or used by any other telephone or telephone operated equipment. Tone dialing is preferred.

503 Meter Selection

CPS Energy has the right to specify the type, kind and size of gas meter to be installed. The assigned Gas Planner sizes gas meters according to **CPS Energy Gas Meter Guidelines**.

To assure proper operation, each gas meter must be the proper size and type for the maximum gas demand and required pressure. The maximum gas demand is determined by adding the Btu input ratings of all gas burning devices that may possibly be operating simultaneously. Furnaces, space heaters, water heaters, boilers, pool heaters, fireplace logs, gas clothes dryers, gas lights, and gas generators should be included at their maximum input ratings.

The type of meter installed can also vary depending upon the Customer's usage factors, e.g., what type of business, hours of operation, critical operations, etc. As a ***rule of thumb***, the factors listed in the following subsections apply for domestic and small commercial loads (Below 3,000 cfh).

Space Requirements

Occasionally, available space will be a factor in selecting the type of meter or meters to be used.

Nature of Customer's Use

The Customer's type of load is a factor in choosing a meter or meters. If the load remains at or near peak load a substantial part of the operating time and the rated capacity of the meter is about the same as the rated load, the next larger meter is often selected. Likewise, while it is important that a meter of sufficient capacity be installed, it is also important from the standpoint of economics not to use a larger meter than is necessary.

On large Industrial Customers or apartment complexes, where it would be inconvenient to cut off gas service, two meters in parallel (combined-consumption) type of metering set-up is often used.

Available Meter Stocks

Normally, a Planner will specify a certain size meter and not a particular make and model. However, occasionally, because of space requirements or accessibility problems, a particular make or model meter must be specified.

Operating Pressure

Gas Meter sets operating at elevated delivery pressures above the standard 7 inches of water column (4 oz.) pressure may require a specific type of metering equipment.

Additional Factors

For larger commercial, manufacturing and industrial loads, as a *rule of thumb*, the following factors *might* apply:

- **Small manufacturing or heavy commercial load (3,000 to 5,500 scfh)**

Require a single “Commercial” type set-up.

Typical dimensions: **5ft X 10ft** footprint.

- **Light manufacturing load (5,500 to 7,000 scfh) OR load where Customer does not have any “critical batching”**

Will usually require a single “Commercial” type set-up.

Typical dimensions: **5ft X 10ft** footprint.

- **Heavy manufacturing or 24 hour operation (greater than 7,000 scfh)**

Require a “Combined Consumption” meter and regulator set-up.

Typical dimensions: **12ft X 14ft** footprint.

Note* The footprint of the meter station is normally dictated by the specific metering equipment being utilized. When a “load and monitor” regulator set up is necessary (See “Note” within *Section 202*), a minimum requirement of 8 pipe diameters of length downstream of the regulators is necessary for sensing lines to accurately measure and meter the Customer’s demand.

The size of gas metering and regulating facilities varies widely depending upon the gas-load needs of different commercial and industrial businesses. **Due to the many determinants associated with meter and regulator selection, it is imperative that the Customer, or the Customer’s agent, contact the assigned CPS Energy Planner in Gas Engineering prior to construction to determine the exact requirements for specific installations, including location and space requirements. Consulting with CPS Energy early in the process may eliminate the need for changes to the gas metering facilities or gas Main Extensions at a later date at Customer expense.**

504 Meter Manifolds

Specific requirements apply where multiple meters are installed or grouped at a single location. These requirements are in addition to the requirements for single meter installations.

CPS Energy will determine whether the installation will have a single manifold or banked manifolds. The Customer or Customer's agent must consult with a CPS Energy representative regarding specific dimensional requirements.

Gas meter manifolds will be limited to one or two tiers. The height of a one tier manifold will be approx. 36" from finished grade to the centerline of the horizontal manifold pipe, and two tier manifolds will not exceed 60" in height. All exceptions will be made at the sole discretion of CPS Energy.

The distance from the centerline of the gas riser to the centerline of the first meter "drop" on the meter manifold will be 8" to 12" depending upon meter size. Subsequent meter drop centerlines will be 14" to 20" along the manifold, with the manifold extending 3" past the final meter drop (refer to Illustration 7.0 below).

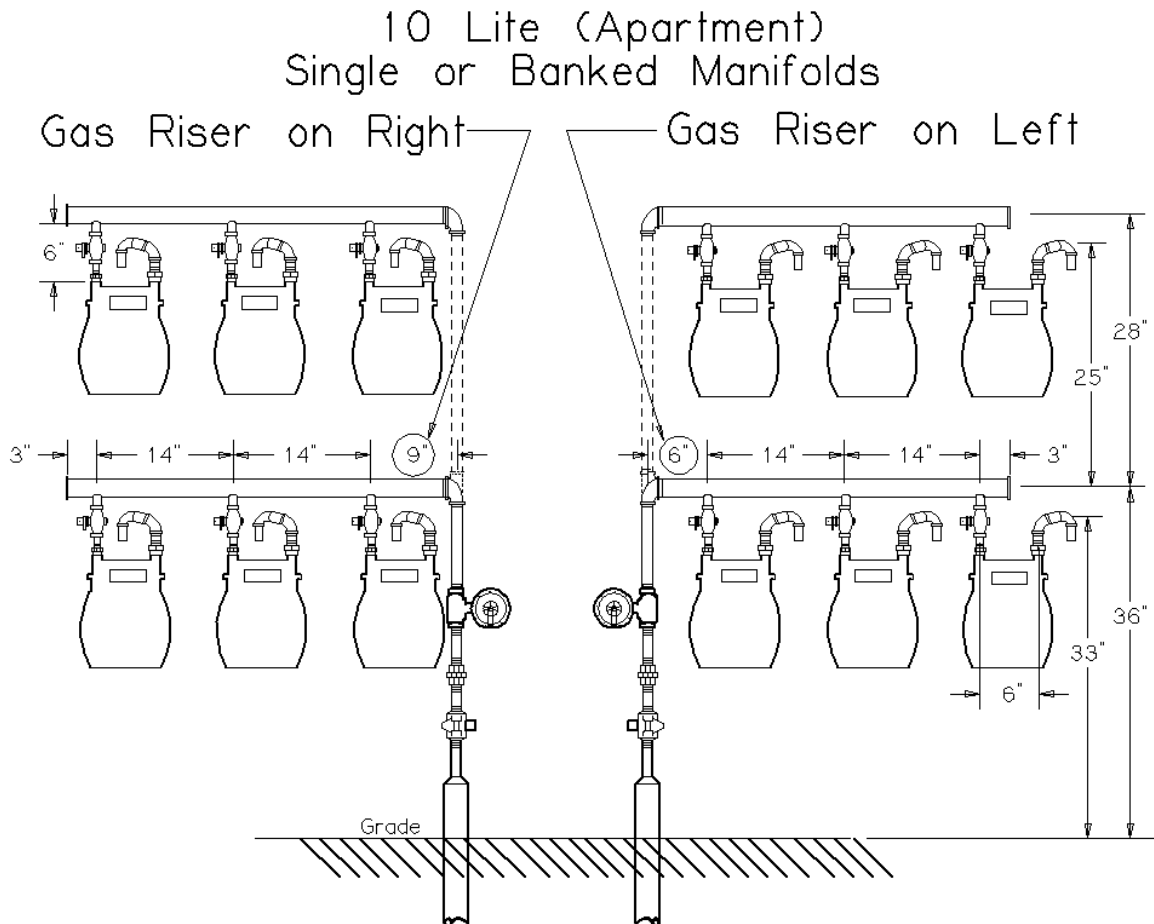

Illustration 7.0 – Typical Multi-Meter Installations and Dimensions

505 Meter Set Location, Requirements and Clearances

1. Gas meter sets must be fully accessible and totally unobstructed.
2. When facing the meter, the gas service riser should be to the left and the Customer owned piping to the right of the meter.
3. The riser must be outdoors and ≥ 12 inches from the final building wall.
4. The meter cannot be located within 3 feet of any door or under and/or within 3 feet of any window that opens.
5. A meter cannot be placed inside living quarters, closets, toilet rooms, bathrooms, restaurant kitchens, over doors, stoves, sinks, sump pumps or other obstructions which make access difficult for installation, servicing, or reading.
6. The meter cannot be located on walls or partitions subject to excessive vibration or which appears to have structural defects of any kind.
7. A meter cannot be installed in places subjected to damage, such as driveways and sidewalks (without suitable protection), within poorly ventilated breezeways, public passages, halls, under porches or decks, in crawl spaces, inside garages, etc., or where subjected to excessive corrosion.
8. Meters cannot be located within 10 feet of a mechanical air intake or "window" installed air conditioner.
9. Meter regulator vents cannot be located within 3 feet of a gravity fresh air intake or air conditioning condenser (compressor).
10. A meter and/or service regulator vent cannot be placed within 3 feet of a source of ignition, such as an open flame or pilot light, an electrical panel, circuit breakers (the CPS Energy electric meter is not considered a source of ignition when installed in an exterior, well-ventilated location), or any other ignition source including a CPS Energy transformer.
11. A meter cannot be located under or near a display platform or show window.
12. A meter cannot be located under *interior* stairways. If allowed by other regulation, *exterior* stairway locations are permitted if open and the horizontal distance between the bottom step and the meter is 4 feet or greater.
13. A meter cannot be located within unventilated engine, boiler, heater, or electrical equipment rooms.
14. A meter cannot be in contact with the soil, in a depression below ground level, or where potentially corrosive materials might contact the meter set.
15. A meter cannot be located where it may cause an obstruction to a Siamese fire connection. An area with a 36 inch radius measured from the center of the connection and extending downward to grade will be kept clear of all associated piping and the gas metering assembly.
16. A meter cannot be located in any cabinet, enclosure or configuration, or near any pipe, cable or objects that could block, or otherwise inhibit, CPS Energy's ability to utilize remote meter reading capabilities.
17. A meter set MUST be plumb and level.
18. A meter MUST be accessible for inspection, reading, testing and shutdown.
19. If located to the right of a window, the gas service riser must be ≥ 8 inches to the right of a window frame. If to the left of a window, the Customer piping entering the structure must be ≥ 8 inches to the left of the window frame.
20. The riser MUST be free of any conditions detrimental to the metering equipment and not in a hazardous or inconvenient location. The space

- around the meter must be clear of obstructions (shutters, doors, rain spouts, concrete equipment pads, shrubbery, porches, patios, decks and gardens).
- 21.** Meters WILL NOT be located over porches or patios.
 - 22.** No mechanical fittings or controls such as water faucets, sewer cleanouts, sprinkler controls, etc. will be located behind or under the meter set..
 - 23.** There MUST be at least 3 feet of clear and level working space maintained in front of the meter. No source of ignition or heat that may damage the meter or meter set can be located nearby. An exception to the 3 feet of unobstructed space would be required protection from vehicular traffic (Section 503).
 - 24.** A meter will not be installed where it will be necessary to remove one gas meter to make possible the removal or installation of another.
 - 25.** Access to enclosed gas meters, except those located in an approved vault supplied by CPS Energy, will be through an opening or door not less than 22 inches by 24 inches, but in no event smaller than specified by CPS Energy.
 - 26.** For multiple meter installations, meters are installed on a manifold when practical. Multiple house pipe fuel runs must be labeled by the Customer in a manner satisfactory to the Administrative Authority and CPS Energy. The marking information must include the authorized apartment, street number, designated building or part of the building being served. The means of marking is to attach an embossed durable metal or plastic tag to each house line.
 - 27.** Enclosures for telecommunication cables, wires, or other equipment along with conduit, pipes, and other wires or cables WILL NOT be installed within an area 12 inches above, behind and extending the entire width of a meter service and riser when the meter is installed adjacent to a structure/building.
 - 28.** The meter set may require a concrete pad if specified by CPS Energy.

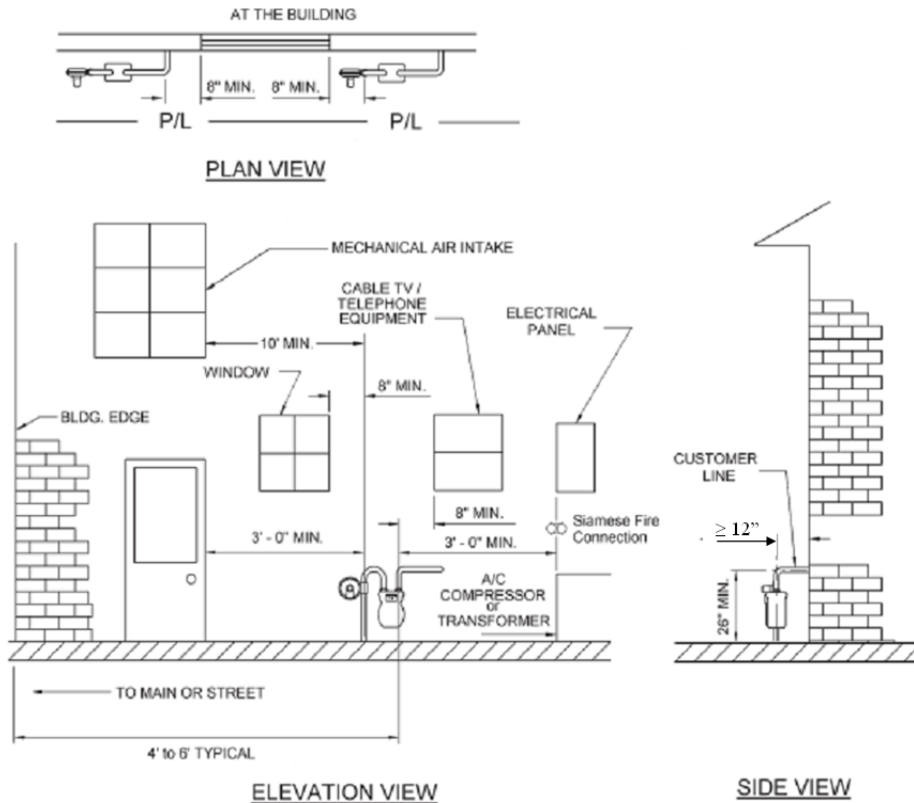

Illustration 3.0 – Typical Meter Set Clearances

506 Meter Set Protection Requirements

Protection from Excess Pressure

Exposing a meter set to pipe testing pressure can damage a meter and/or regulator. A Customer/Contractor that performs a pressure test on house pipe connected to a diaphragm or rotary meter is responsible for the cost to repair or replace the CPS Energy meter(s) and/or regulator(s).

On larger meter sets it is recommended that a Customer install a valve immediately downstream of the meter set to protect the meter and regulator during a pressure test of the Customer owned piping. School facilities subject to State mandated periodic testing of their piping would be well advised to install such a valve.

Protection from Physical Contact

Protection from tampering, vehicular contact and vandalism are Customer responsibilities to be installed and paid for by the Customer. Protection includes, but is not limited to, bollards, fences, permanently installed planters, large trees or other similar permanent structures. Wheel stops, wooden posts and removable barriers are not considered acceptable substitutes.

CPS Energy should be consulted about the type and extent of protection. If the Customer cannot provide protection, CPS Energy will provide it at Customer expense. **Meter(s) will be installed but not activated until required protective measures are in place.**

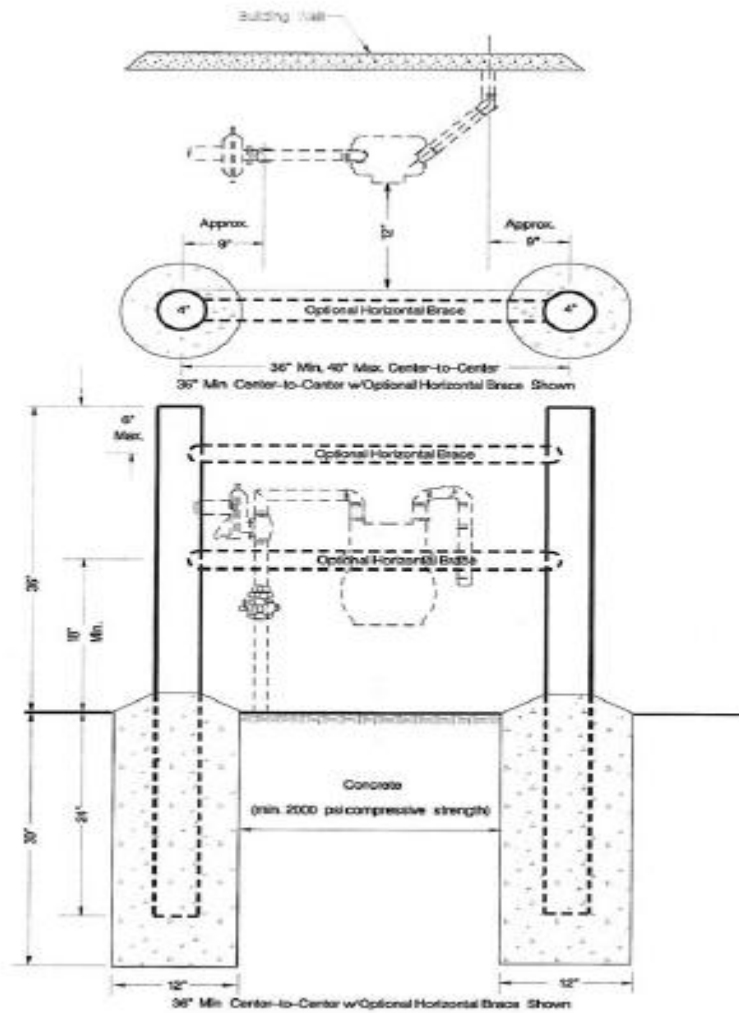

Illustration 4.0 – Typical 4 Inch Gas Meter Guard

Gas meter sets located in the following areas **must** be protected:

1. Within 3 feet of single-family residential driveways or parking areas (including garage areas), commercial refuse container locations, or thoroughfares or paved areas with curbs 6 inches or higher. Bollards constructed of standard 4" diameter steel pipe (\geq schedule 20), encased in 12" x 12" x 30" deep concrete footers and extending 2 feet below and 3 feet above final grade are considered adequate protection. Minimum compressive strength of the concrete will be 2,000 psi. Bollards should be level and plumb.
2. Within 8 feet of multi-family, commercial, or industrial driveways or parking areas, loading docks or freight handling areas, or thoroughfares or paved

areas without curbs, bollards constructed of standard 6" diameter steel pipe (\geq schedule 20), encased in 15" x 15" x 36" deep concrete footers and extending approximately 2 1/2 feet below, and 3 feet above final grade are considered adequate protection. Minimum compressive strength of the concrete will be 2,000 psi. Bollards should be level and plumb.

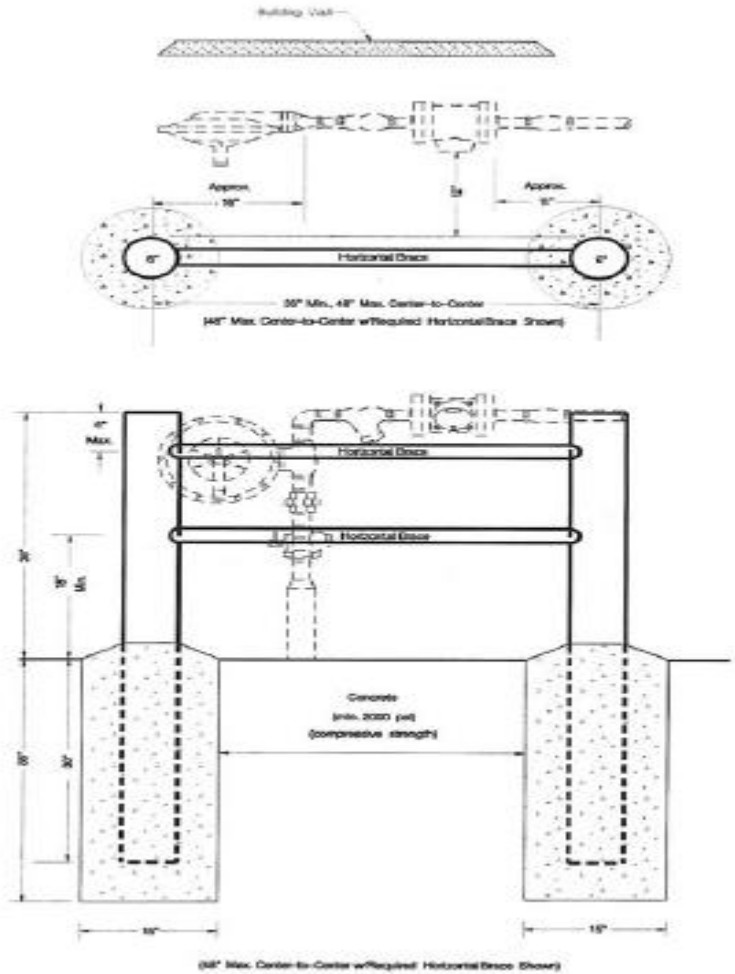

Illustration 5.0 – Typical 6 Inch Gas Meter Guard

3. 3 to 4 feet of center to center spacing between bollards is optimal. If the protected space will be greater than 4', the protective barrier should be extended and an additional bollard installed so the final length is equally spaced between bollards 3' to 4' from center to center. Bollards with 4 foot center-to-center spacing must have 2 (more for added strength) horizontal braces constructed of 2" diameter steel pipe (\geq schedule 20) installed from bollard to bollard by welding same in place. The center of the upper horizontal brace should be \leq 6" below the top of the bollards and the center of the lower brace \geq 18" above final grade. Any additional horizontal brace(s) should be equidistant between the upper and lower braces.

4. If a building wall provides adequate protection to a meter, bollards are only required on the side of the meter set subject to possible damage.
5. The Customer should consult with CPS Energy regarding clearances for Meter sets that require protection on more than one side, including complete encirclement.
6. Bollards MAY NOT be driven.
7. Bollard installation requires a call to the National One Call Center prior to digging (dial 811 and allow 48 hours notice).
8. Measures must be taken to protect gas metering assemblies from willful damage, vandalism and unauthorized tampering. Decorative wrought iron, chain link, brick, masonry, wooden privacy fencing, etc., will help restrict access to a meter set. Complete enclosure or encirclement may be required.
9. CPS Energy personnel must have independent access through an enclosure but will not accept or hold a Customer's keys. Consequently, the enclosure must be locked using a double-lock arrangement with one lock provided for and by the Customer and one lock provided for and by CPS Energy.

Protecting Large Capacity Meter Sets

For larger (8C or larger) commercial, manufacturing and industrial gas meter installations the following parameters apply:

Location & Accessibility

The gas meter location **must** be accessible to the trucks and heavy equipment necessary for CPS Energy to install and maintain the meter set. Often, for this very reason, it is advisable to locate large gas meter sets away from building(s) or other obstructions (See illustration this section). It is also **highly advisable** that a meter location be established through coordination with CPS Energy while the project is in the preliminary planning stages and **before** detailed design of the facility and awarding of the plumbing contract.

Detached Enclosure

If a detached enclosure is planned, the measurements of the enclosure will vary based upon the size of the metering equipment. Therefore, it is **highly advisable** that the topic be addressed through coordination with CPS Energy while the project is in the preliminary planning stages and **before** detailed design of the facility and awarding of a plumbing contract. Regardless, access to the enclosure will be through an 8 foot wide (minimum) entryway.

The enclosure may be constructed of materials appropriate to the surrounding architecture or landscaping.

CPS Energy personnel must have independent access to the enclosure. CPS Energy personnel will not accept or hold a Customer's keys. Consequently, the meter enclosure must be locked in one of the following ways:

- Using a double-lock arrangement with one lock provided for, and by, the Customer, and one lock provided for, and by, CPS Energy.

- Using an acceptably located key box, provided and installed by the Customer, to hold the Customer's key.

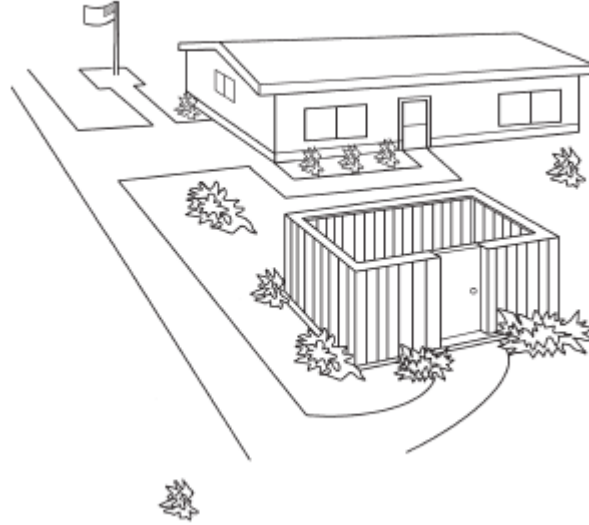

Illustration 8.0 – Typical Detached Enclosure

507 Cabinet & Metering Room Requirements

General Requirements

If it is not possible to provide a suitable meter location outside the building, a meter enclosure (*i.e.*, meter room or meter cabinet) may be required. All meter rooms and cabinets must be designed to prevent gas migration into the building, and must be accessible to CPS Energy personnel at all times. The Authority Having Jurisdiction and CPS Energy must approve the location and design of meter rooms and cabinets. Except in such cases where an approved vault is supplied by CPS Energy, the Customer is responsible for furnishing and installing the gas meter room or cabinet and all related openings, louvers or windows.

Only residential-size meters may be installed in cabinets. Larger meters requiring an enclosure must be installed in a meter room or a detached enclosure.

Meter Cabinets

CPS Energy will provide the Customer with the minimum cabinet enclosure size (See illustration this section). Cabinet enclosure size is based not only on the size of the meter currently required, but also on the potential size of a larger meter that could be required to meet future needs. The following additional requirements must also be met:

- The inside of the cabinet enclosure must be free of any partitions or bracing. Studding is permitted along the front of the cabinet, but studs must be arranged on thirty (30) inch centers to not interfere with meter reading or access.
- Meters must be accessible from a door that opens to the cabinet enclosure. A door that opens from the outside of the building is preferred.
- The cabinet enclosure door must be louvered or otherwise vented at the top and bottom and must be side-hinged to permit it to open 90° or more. CPS Energy also requires an opening in the door or cabinet to permit the meter index to be read without opening the door.
- That portion of the Customer owned piping that connects to the gas meter facilities is the only Customer-owned equipment or facility permitted within the gas meter cabinet enclosure.
- Electric devices and connections for services such as cable television or telecommunications must not occupy the gas meter cabinet enclosure under any circumstances.

Cabinet installations must also comply with local ordinances, adopted codes, or requirements.

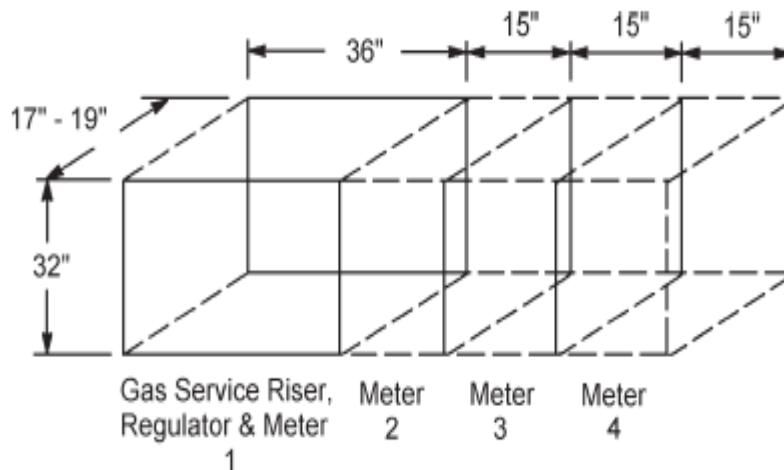

Illustration 6.0 – Cabinet Dimensions for Multiple Residential Meters

Meter Rooms

When required, the Customer will provide a specially designated room for CPS Energy’s meter(s). The Customer-owned piping will terminate in this room and CPS Energy’s meter(s) will be located in this room.

The meter room must be well lit with explosion proof lighting equipment per Class 1, Division 2, Group D standards of the National Electric Code and be accessible to CPS Energy personnel at all times. Customers must construct meter rooms with doorways opening to the outside of the buildings or into areas accessible to the general public.

Meter room construction must have a minimum fire rating of one hour and be completely sealed from the rest of the building. An airtight door is also required if the doorway leads from the meter room to an area inside the building. Penetration points through the floors, walls and ceilings of meter rooms must be vapor-proof sealed, and can be designed and installed in accordance with all applicable regulations, as set forth in federal, state and municipal codes.

A sealed port into the meter room that can be safely accessed from the outside must be installed to allow a technician to use a methane detection instrument to determine the concentration of natural gas, if any, before entering the room. The port must be a ½-inch NPT-sized coupling with a cap, penetrate completely through the wall of the meter room, and be sealed to the wall to prevent leakage in or out. The port must be accessible at all times and be located seven feet from the surface of the floor or one (1) foot from the ceiling if the meter room is less than seven feet high. If an airtight door is necessary, the port must be installed on the same meter-room wall as the door.

Meter rooms located within a building may be locked if the Customer provides CPS Energy with independent access to the room. CPS Energy personnel will not accept or hold a Customer's keys. Consequently, the meter room must be locked in one of the following ways:

- Using a double-lock arrangement provided by the Customer, with one lock for the Customer and one lock for CPS Energy.
- Using an acceptably located key box, provided and installed by the Customer, to hold the Customer's key.

The meter room must not contain sources of ignition. Do not put electric meters in gas meter rooms. The Customer may, however, request CPS Energy's approval **in advance** to put electric wiring and equipment in the meter room. This equipment must meet the requirements of the National Electric Code for installation in Class 1, Division 2 areas. Approved electric wiring and equipment must not interfere with gas metering equipment operation or maintenance. Switches located outside of the room are not required to be explosion-proof.

The room must have at least two fresh air vents to the outside. The Customer must install one (1) vent near the top of the room and at least one vent near the bottom of the room and arrange the vents to provide cross-ventilation to avoid the recirculation of vented gas. The total area of the vents must be a minimum of thirty square inches per one hundred cubic feet of volume in the meter room, but WILL NOT be less than one hundred square inches.

Where venting of the service regulator is necessary, the Customer must locate gas meter sets in a position that allows the gas regulator to vent to a safe,

outside location that meets the requirements found in *Section 504, Service Regulator Vent Requirements*. CPS Energy must place the gas regulator in a position to minimize the length of the regulator vent line and allow adequate venting capacity. An Engineer from CPS Energy Gas Business Unit must approve the location of the regulator within the room and the length of the vent line. For this reason, the Customer should consult with CPS Energy for specific requirements.

508 Communications Enclosures

An enclosure for the termination or connection of telecommunication equipment cables, wires or other equipment **WILL NOT** be installed within an area 12 inches above, and extending the entire width of, the gas meter and service facilities, including the gas service riser. Also, the area immediately behind the gas meter, service facilities and risers, and between those facilities and the premises or structures being served will be kept free and clear of all other facilities or equipment such as pipes, wires, cables or conduits.

509 Service Regulator Vent Requirements

Indoor CPS Energy regulators are installed only when absolutely necessary. Their vents will be extended to a safe, remote outside location with the vent opening facing downward with a rust-proof screen over the vent opening.

Gas meter sets **MAY NOT** be installed where the service-regulator vent terminates in any of the following areas:

1. Within a rectangular area extending 18 inches either side of, and 10 feet below, any air vent or opening window that connects to a habitable space in a building or any space likely to contain a source of ignition.
2. Within 3 feet of an opening (excluding windows) used as an outside air intake for ventilation, where venting gas could be drawn into a building or an enclosed space under an occupied portion of a building. Vents located within 10 feet (measured horizontally) of an air intake will terminate at least 3 feet above the highest point of the air intake. Dryer vents and windows are not considered air intakes, but a reasonable distance should be allowed between them and the regulator vent.
3. Within 3 feet of any source of ignition.
4. Under a display platform or show window in commercial buildings, including any permanent, elevated, display floors or platforms associated with the window where the purpose of the window is to present a display to the public.
5. Under building overhangs where the overhang is likely to direct venting gas to a building opening.

In areas subject to flooding, the regulator vent(s) will terminate at least 1 foot above the 100-year base flood elevation. These assemblies may also be required to have additional protection from damage due to floating debris during a flood. This protection will be the Customer's responsibility.

510 Electric Bonding & Grounding of CPS Energy Owned Gas Pipe

CPS Energy's gas piping system is electrically isolated from Customer facilities and WILL NOT be used as a grounding electrode. Attaching, electrically bonding, hanging or supporting any object from the gas service piping, risers or meter facilities is strictly prohibited.

600 Customer Requirements and Responsibilities

601 Application for Service

The Customer will make an Application for Service with CPS Energy, establish credit, and make deposits as may be required by CPS Energy before CPS Energy schedules construction. The Customer will agree to abide by the CPS Energy Policy for Gas Main Extensions & Service Installations (Effective 1-1-2006), the CPS Energy Rules and Regulations Applying to Retail Electric and Gas Service, and the CPS Energy Policy for Miscellaneous Customer Charges in order to receive service. A Service Agreement may be required which specifies different or additional Customer responsibilities.

CPS Energy may refuse applications for new gas service or the turning on of existing gas service upon reasonable grounds.

602 Ownership and Responsibility

The Customer will design, own, install, operate and maintain all facilities beyond the CPS Energy point of delivery (Customer's "house line" or "yard line"). CPS Energy will not size Customer-owned gas piping systems.

CPS Energy is not responsible for loss or damage caused by a Customer's negligence, improper care or wrongful act in maintaining their house line. The Customer's facilities must conform to and comply with the applicable laws, codes, and ordinances of all governmental authorities having jurisdiction.

The Customer may repaint the exposed CPS Energy owned piping and meter for aesthetic reasons. However, care must be taken NOT to paint over dials, reading devices, or vent line openings.

Customer gas piping that is subject to corrosion should be protected by the Customer. All above ground piping should be painted to protect it from atmospheric corrosion. All underground metallic piping should be coated and cathodically protected. All piping passing through an outside wall should also be protected against corrosion by coating or wrapping with an inert material approved for such applications. Underground piping, where installed below grade through the foundation or basement wall of a building, should be encased in a protective sleeve. The space between the gas piping and the sleeve should be sealed to prevent the entry of gas, water, insects or rodents.

CPS Energy has the right to refuse or cease to deliver gas to any Customer if any part of the house pipe or equipment will at any time be unsafe or if use of the piping or equipment is prohibited by law, municipal ordinance or regulation.

CPS Energy does not assume the duty of inspecting the Customer's piping, appliances or equipment and assumes no liability for said piping, appliances or equipment.

Natural gas service will not be supplied to an apparatus or appliance where the operation will be detrimental to the CPS Energy gas system or other Customers. Gas service will be discontinued to Customers who continue to use such apparatus or equipment after being notified.

603 Yard Lines

All piping downstream from the CPS Energy gas meter set is Customer owned piping and is the responsibility of the Customer to maintain at Customer cost. This maintenance should include periodic leakage surveys using leak detection equipment.

Gas piping (above or below ground) supplying more than one building on any one premises must be equipped with separate shut-off valves to each building, so arranged that the gas supply can be turned on or off to any individual or separate building. The shut-off valve must be located outside the building it supplies and must be readily accessible at all times.

All excavations required for the installation of underground piping will be kept open until the piping has been inspected and approved. If any such piping is covered or concealed before inspection and approval, it will be exposed upon the direction of the Authority Having Jurisdiction.

604 Pressure Loss & Load Characteristics

The design pressure loss in any Customer owned piping system under maximum probable flow conditions, from the Point of Delivery to the inlet connection of the gas utilization equipment, will be such that the supply (delivery) pressure at the equipment is greater than the minimum pressure required for proper equipment operation (International Fuel Gas Code (IFGC) – latest Edition; Section 4.2.1).

CPS Energy will provide a gas service, meter and regulator set capable of meeting the Customer's maximum demand (diversified if applicable). Delivery pressure will be checked, under load, at the outlet side of the meter set or the Point of Delivery at the request of the Customer. If the observed pressure droop is within acceptable limits under a steady load, the Customer will be considered receiving natural gas in accordance with CPS Energy's rate schedule.

CPS Energy will not be responsible for controlling pressure loss associated with inadequately designed or constructed Customer owned piping, facilities and equipment downstream from the meter set. For this reason it is strongly urged that Customer owned piping systems are designed in accordance with Chapter 4 of the latest Edition of the International Fuel Gas Code (IFGC).

Short term pressure spikes, pulsations or sudden changes in gas flow, back-flow conditions or droop resulting from the instantaneous on or off action of the Customer's equipment will be the Customer's responsibility to correct at their cost. In addition, CPS Energy gas metering and regulating equipment can be damaged by these conditions and the Customer is responsible for the expense of repairing or replacing CPS Energy equipment. Natural gas service will not be supplied to an apparatus or appliances where their operation will be detrimental

to the CPS Energy gas system or other Customers, so Customers will install, at their expense, any equipment necessary to mitigate or eliminate such detrimental effects. CPS Energy must review and approve these installations before initiating service and after a Customer effects a change in operation.

605 Easements

The Customer will provide or secure easements, as requested by CPS Energy, for gas distribution lines/equipment installed on private property at no cost to CPS Energy and without the need for condemnation by CPS Energy.

606 Permits

The Customer will be responsible for obtaining permits and approvals for the Customer's project before CPS Energy schedules construction. If CPS Energy is required to obtain permits or approvals to gain access to easements or properties owned or otherwise controlled by railroads, state highways, commissions, City or other entities and agencies in connection with the Customer's project, then the total costs incurred by CPS Energy in gaining such permits and approvals will be included in the estimated Standard Design Facilities Costs.

607 Site Preparation

The Customer will perform site preparation if requested by CPS Energy, such as clearing the rights-of-way and easements of trees, tree stumps, brush, ornamental shrubs and other obstructions, including tree trimming, in accordance with applicable governmental agency requirements. The Customer will grade the rights-of-way and easement to final grade before CPS Energy will schedule construction. The Customer will stake property pins, property lines, easements and rights-of-way lines as requested by CPS Energy and will maintain clearing, grading and staking during construction by CPS Energy. Any work required of CPS Energy for adjustments to grade or alignment caused by the act(s) of the Customer will be performed by CPS Energy at the Customer's expense. CPS Energy may, at its option, cease or delay the installation of gas facilities until the Customer's construction has reached a foundation stage or continuous construction is, in CPS Energy's determination, satisfactorily progressing on the premises, buildings or dwelling units to be served.

608 Protection

Refer to Section 506.

609 Required Information for Requesting Service

To initiate the CPS Energy Planning and Construction process for Gas Service Installation, the Customer needs to provide the following:

- Two (2) hard copies of signed and sealed engineered drawings for the project. The site plan should include a proposed meter location, desired route

of gas service line, location of other on-site utilities, and drainage on Customer's property.

- A connected load summary or equipment schedule and operating pressures for all equipment.
- The desired delivery pressure. Contact person/general contractor information.
- Estimated date(s) that gas service will need to be constructed and the meter set activated.

610 Request to Remove a Service

To request the removal of a gas service, call CPS Energy at (210) 353-3333.

611 Qualified Agency

Installation and replacement of Customer gas piping, gas utilization equipment or accessories, and repair and servicing of equipment will be performed only by a Qualified Agency.

612 Master Metered Systems

A Master Meter Operator is defined as the owner, operator, or manager of a master metered system.

A Master Metered System is a pipeline system (other than one designated as a local distribution system) for distributing gas within, but not limited to a definable area, such as a manufactured home park, housing project or apartment complex, where the operator purchases metered gas from an outside source (such as CPS Energy) for resale through a gas distribution pipeline system. The gas distribution pipeline system supplies the ultimate Customer who either purchases the gas directly through a sub-meter or by other means such as rents.

As per Title 16, Texas Administrative Code (TAC) Chapter 8, RULE §8.220 Master Metered Systems:

- 1) Compliance with minimum standards is required. Master meter operators will comply with the minimum safety standards in 49 CFR Part 192.
- 2) Leakage survey. Each master meter operator will conduct a leakage survey on the system every 2 years using leak detection equipment. CPS Energy does not provide nor is responsible for these services.
- 3) Overpressure equipment. Natural gas suppliers will be responsible for installation and inspection of overpressure equipment at master meter locations where 10 or more consumers are served low pressure gas.

700 Technical References

701 Quality of CPS Energy Natural Gas

Gas delivered by CPS Energy should generally:

- not contain more than one-quarter (1/4) of one (1) grain of hydrogen sulfide or more than five (5) grains of sulfur per one hundred (100) cubic feet.
- have a total Gross Heating Value of not less than nine hundred fifty (950) Btus per cubic foot of gas as calculated on a saturated basis.
- not exceed a hydrocarbon dew point of forty (40) degrees Fahrenheit;
- not have a temperature greater than one hundred twenty (120) degrees Fahrenheit or less than forty (40) degrees Fahrenheit;
- not contain more than two (2) percent by volume of carbon dioxide;
- not contain more than two (2) percent by volume of nitrogen;
- not contain more than ten (10) parts per million by volume of oxygen;
- not contain more than four (4) percent by volume of nonhydrocarbon gases;
- be commercially free of all liquids, suspended matter, dust, all gums and gum forming constituents, and other objectionable substances;
- not contain more than seven (7) pounds of H₂O vapor per one million (1,000,000) cubic feet; and
- not contain any substances in any amount which violate any applicable laws, orders, rules, and regulations, of any jurisdictional authority with jurisdiction hereof.

702 Conversion Factors

CPS Energy natural gas is billed to the Customer in CCF. If it becomes necessary to convert from one unit to another, the following information might be helpful:

1 Btu = Energy required to raise temperature of one pound of water 1 degree Fahrenheit

1 CF (cubic feet) Natural Gas = 1000 Btu = 1 MBtu

1 CCF (100 cubic feet) = 100 CF = 1 Th (therm) = .1 Mcf = 100,000 Btu

10 CCF = 1000 CF = 10 therms = 1 DTh (dekatherm) = 1 Mcf = 1,000,000 Btu = 1 MMBtu

1 quad = 1,000,000,000,000,000 (quadrillion) Btu or 1,000,000,000 MMBtu

$$\text{Therms} = \text{CCF} \times \frac{\text{Btu / CCF}}{100,000\text{Btu / therm}}$$

$$\text{Therms} = \text{MCF} \times \frac{\text{Btu / CCF}}{100,000\text{Btu / therm} \times 10}$$

$$\text{CCF} = \text{Therms} \times \frac{100,000 \text{ Btu / therm}}{\text{Btu / CCF}}$$

$$\text{MCF} = \text{Therms} \times \frac{100,000 \text{ Btu / therm} \times 10}{\text{Btu / CCF}}$$

703 Pressure Conversion Table

Ounces	Inches of Water	Inches of Mercury	lb/in ² (PSI)	Pascals (PA)
0.29	0.51	0.04	0.02	126.97
0.44	0.76	0.06	0.03	189.21
0.58	1.01	0.07	0.04	251.46
1.00	1.73	0.13	0.06	430.71
2.00	3.46	0.25	0.12	861.42
3.01	5.2	0.38	0.19	1294.62
4.01	6.93	0.51	0.25	1725.33
5.01	8.66	0.64	0.31	2156.04
6.01	10.39	0.76	0.38	2586.75
7.01	12.12	0.89	0.44	3017.46
8.01	13.85	1.02	0.50	3448.17
9.01	15.59	1.15	0.56	3881.37
10.01	17.32	1.27	0.63	4312.08
11.01	19.05	1.40	0.69	4742.79
12.01	20.78	1.53	0.75	5173.50
13.02	22.52	1.66	0.81	5606.70
14.02	24.25	1.78	0.88	6037.41
15.02	25.98	1.91	0.94	6468.12
10.24	17.71	1.30	0.64	4409.18
16.01	27.7	2.04	1.00	6896.55
20.02	34.63	2.55	1.25	8620.69
24.02	41.55	3.05	1.50	10344.83
32.02	55.4	4.07	2.00	13793.10
36.03	62.33	4.58	2.25	15517.24
40.03	69.25	5.09	2.50	17241.38
44.03	76.18	5.60	2.75	18965.52
48.04	83.1	6.11	3.00	20689.66
52.04	90.03	6.62	3.25	22413.79
56.04	96.95	7.13	3.50	24137.93
60.05	103.88	7.64	3.75	25862.07
64.05	110.8	8.14	4.00	27586.21
72.05	124.65	9.16	4.50	31034.48
80.06	138.5	10.18	5.00	34482.76
88.07	152.35	11.20	5.50	37931.03
96.07	166.2	12.22	6.00	41379.31
112.08	193.91	14.25	7.00	48275.86
128.10	221.61	16.29	8.00	55172.41
144.11	249.31	18.32	9.00	62068.97
160.12	277.01	20.36	10.00	68965.52

704 Pressure Conversion Formulae

- Ounces = $.578036669 \times$ Inches Water
- PSI = $0.0361 \times$ Inches Water
- Pascals = $248.965517 \times$ Inches of Water
- Inches of Mercury = $.0734996 \times$ Inches Water