



NEW RESIDENTIAL APPLICATION AND PROCESS INFORMATION PACKET

Residential Electric and Gas Process Information



Customer submits application. IDS Specialist reviews application and documents.

Is Application Complete?

Yes

IDS Specialist will process application within 2 business days, assign to designer, and notify customer.

No

IDS Specialist contacts customer within 2 business days and advises of any missing documents that are needed.

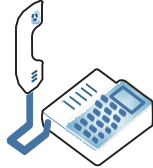

Valid form of identification is required such as Social Security card, Government/State issued ID or Driver's License, Proof of Residency- if not from US (Passport & Matricula not accepted).



Customer should apply for all necessary permits with your city or municipality, such as the City of San Antonio at 210-207-1111. If you are in an incorporated area, please contact your municipality.

Designer contacts customer within 2 business days to discuss work request, provide contact information, and share the standards durations for design & construction, which vary based on the type of work request.



Once site is ready, customer clicks site ready in C&R Web Portal, calls 210-353-4050, or the assigned designer for the project to advise the site is ready for construction to begin.

Construction will begin only after following conditions are met:

- Payment is remitted & received
- Sign and return any required easements to CPS Energy
- Necessary permits/inspections are completed & released
- Address clearly posted at site
- Site within 6" of final grade, cleared of debris, & accessible
- Meter loop built & installed securely on wall
- Trees trimmed to provide at least 10 ft of radial clearance around above ground electric & gas facilities
- Conduits & conductors on the load side of the meter can be installed
- The gas house pipe must be stubbed out 26" above final grade

For additional information, see Site Ready Service Standards.



Common Service Delay reasons:

- Unapproved meter can is installed
- Electric & Gas too close together
- Gas meter/regulator are located under vent or window
- Meter can is on wrong side of home
- Home is sheet rocked before gas inspection complete
- No raceway straps
- UG Electric Service exceeds 250 ft
- OH Electric Service exceeds 100ft
- Slope ratio is not 3 to 1 & not at final grade
- No address posted at site

If site is turned down, inspector will leave a notice at meter can & customer is notified by email within 24 hours. Once the issue is resolved, customer can notify CPS Energy to reschedule new site inspection or relick site ready on the C&R Web Portal. The construction date will be adjusted to accommodate construction delay.



General Addressing Information

For Addresses in the City of San Antonio

- The City of San Antonio assigns addresses within city limits. A service address must be assigned prior to the installation of an electric or gas service. An Address Verification Letter may be required if service address is not verifiable. This letter is supplied by the City of San Antonio.
- For an assignment of a new address or for an Address Verification Letter, you can submit the form by clicking on the following link: <https://docsonline.sanantonio.gov/FileUploads/dsd/RequestforAddress.pdf> and submitting to the City of San Antonio's Development Services Addressing Team, either in person at 1901 South Alamo or via email at dsd.addressing@sanantonio.gov. For further information, please contact their Land Entitlements Addressing Team at (210) 207-1111.

Outside of City Limits in Bexar County

- CPS Energy assigns addresses outside of City Limits, in Bexar County
 - **Important:** If the address is outside of city limits one of the following documents are required to assign your address:
 - Property survey **OR** Plat with legal description
 - **EXTRATERRITORIAL JURISDICTION (ETJ) APPROVAL/ CERTIFICATE OF DETERMINATION:** If you are outside San Antonio city limits, you may still be within San Antonio's ETJ. It is suggested that you contact the Development Services Department of the City of San Antonio prior to obtaining any other releases for electrical service. Please contact the City of San Antonio at the Business and Development Services building, 1901 S. Alamo St., (210)-207-1111.

Incorporated Cities That Assign Their Own Addresses

Important: For addresses in an incorporated city, an address verification letter may be required if service address is not found in our system. This letter is supplied by the incorporated city. See list of incorporated cities and contact information.

CITY	EMAIL/WEBSITE	PHONE #	ADDRESS
Alamo Heights	nshealey@alamoheightstx.gov	210-826-0516	6116 Broadway San Antonio TX 78209
Balcones Heights	bhtx.gov/departments/city-secretary	210-735-9148	3300 Hillcrest Dr. Balcones Heights, TX 78201
Castle Hills	cs@castlehills-tx.gov	210-293-9675	209 Lemonwood Castle Hills, TX 78213
Hill Country Village	www.hcv.org	210-494-3671	116 Aspen Ln San Antonio, TX 78232
Hollywood Park	jalamia@hollywoodpark-tx.gov	210-494-2023	2 Mecca Dr. Hollywood Park, TX 78232
Leon Valley	s.pass@leonvalleytexas.gov	210-684-1391	6400 El Verde Rd. Leon Valley, TX 78238
Olmos Park	citysecretary@olmospark.org	210-824-3281	120 W El Prado San Antonio, TX 78212
Terrell Hills	www.terrell-hills.com/contact-us	210-824-7401	5100 N New Braunfels Ave San Antonio, TX 78209
Windcrest	rdominguez@windcrest-tx.gov	210-655-0022	8601 Midcrown Windcrest, TX 78239
Live Oak	dgoza@liveoaktx.net	210-653-9140	8001 Shin Oak Dr. Live Oak, TX 78233
Schertz	customercare@schertz.com	210-619-1750	1400 Schertz Pkwy Schertz, TX 78154
Universal City (Commercial)	ACM@UCTX.Gov	210-659-0333	2150 Universal City Blvd Universal City, TX 78148
Atascosa County	911arap@atascosacounty.texas.gov	830-769-2748	711 Broadway Jourdanon, TX 78026
Medina County	medinacoordinator@gmail.com	830-741-8997	1613 Ave K Ste. 101 Hondo, TX 78861



CPS Energy Addressing Requirements for Meter Installation

CPS Energy crews make every effort to assure your meter installation is completed accurately and ready for you when you need it.

To assure there are no delays when submitting your request for a meter installation, please follow the addressing requirements below:

Temporary Meter Loops

- Brace of Temporary tripod - Full Address to include the #T at the end of the address should be stenciled in black paint on the brace of the temporary tripod

Or

- Breaker panel – house number with #T stenciled in black paint

Residential & Commercial Permanent Structure – Single Meter

- Residential Structure has permanent address and Meter Loop is on structure – no additional addressing requirement is needed
- No Address on Residential Structure – Can have address on a sign in front window – (Residential Only) or on Meter Can or Disconnect Panel with full address stenciled in black paint
- Residential Meter Pole – Full address should be stenciled in black paint on meter can or disconnect panel
- Commercial Structure with or without a Permanent Address and Meter Loop on Structure – Full address should be stenciled in black paint on meter can or disconnect panel

Residential & Commercial Permanent Structure – Multi-Meters (example Duplex)

- Structure has permanent address and Meter Loop is on structure – Each Meter Can or Disconnect Panel will need to be labeled with Suite/Apt number only stenciled with black paint. Full address should be on Main Disconnect or Meter Trough.
- No Address on Structure – Each Meter Can or Disconnect Panel or Trough should have full address stenciled in black paint to include Suite/Apt. number for that can/panel
- Residential or Commercial Structures with a Meter Rack – Full address should be on trough lid or disconnect stenciled in black ink

WORKING CLEARANCE REQUIREMENTS FOR GAS SERVICE EQUIPMENT

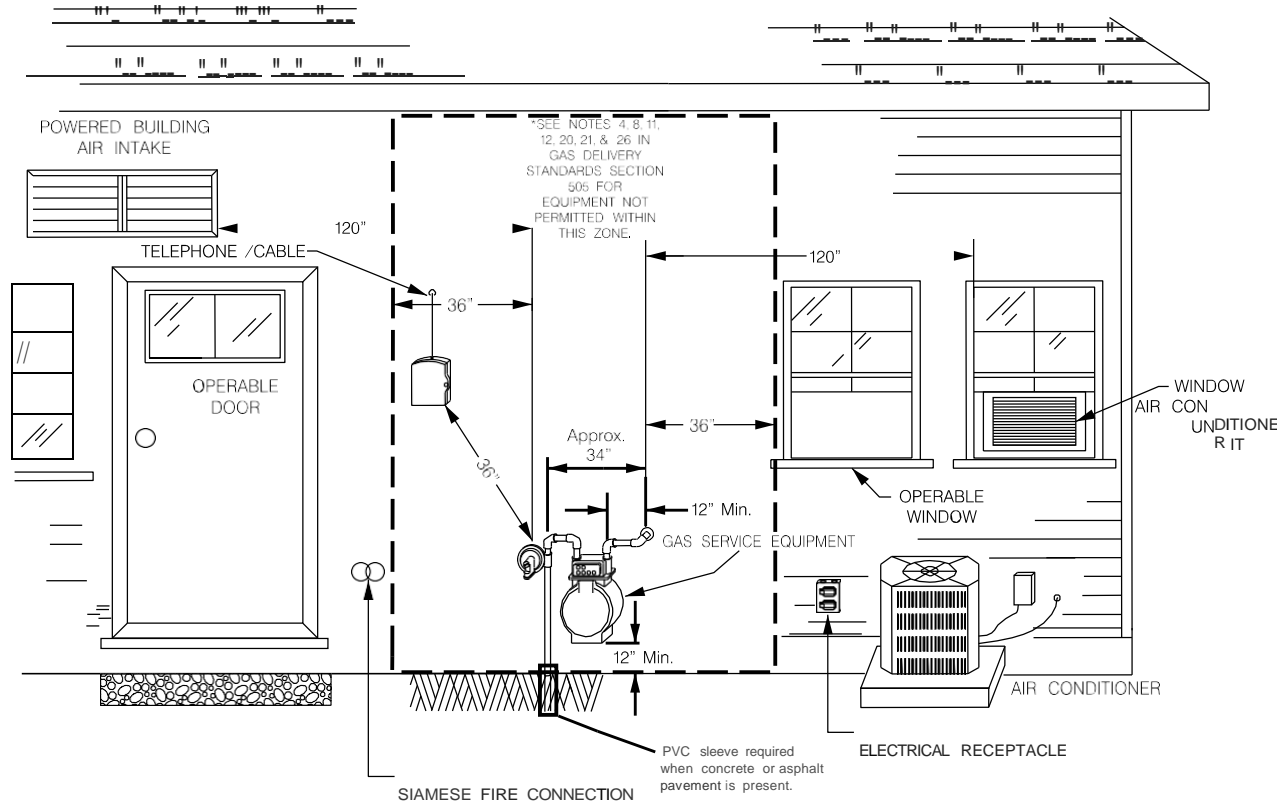

Edge of Building Clearances

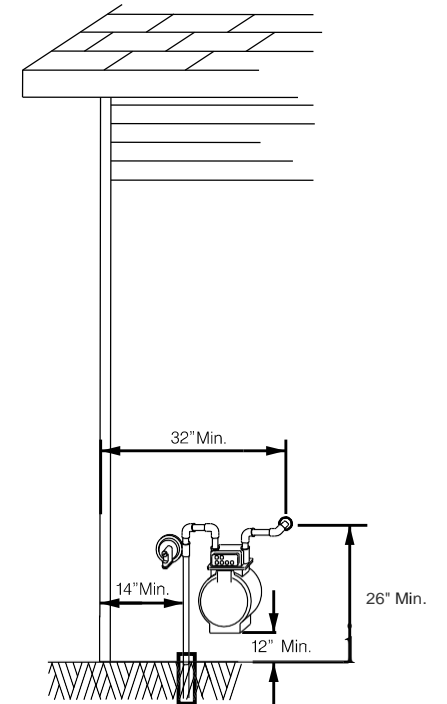

* Note: Other clearances on this drawing apply.

Note: Building must be free of drywall at time of visual inspection .

*Refer to latest version of "Gas Service Standards" for additional notes.

	Date	Approved
Issued	1Q12/19	R.E.
Revised	1o&19	

CPS ENERGY
CONSTRUCTION STANDARD
(GAS)

G-S-700-1-1

Temporary Meter Installation- Overhead

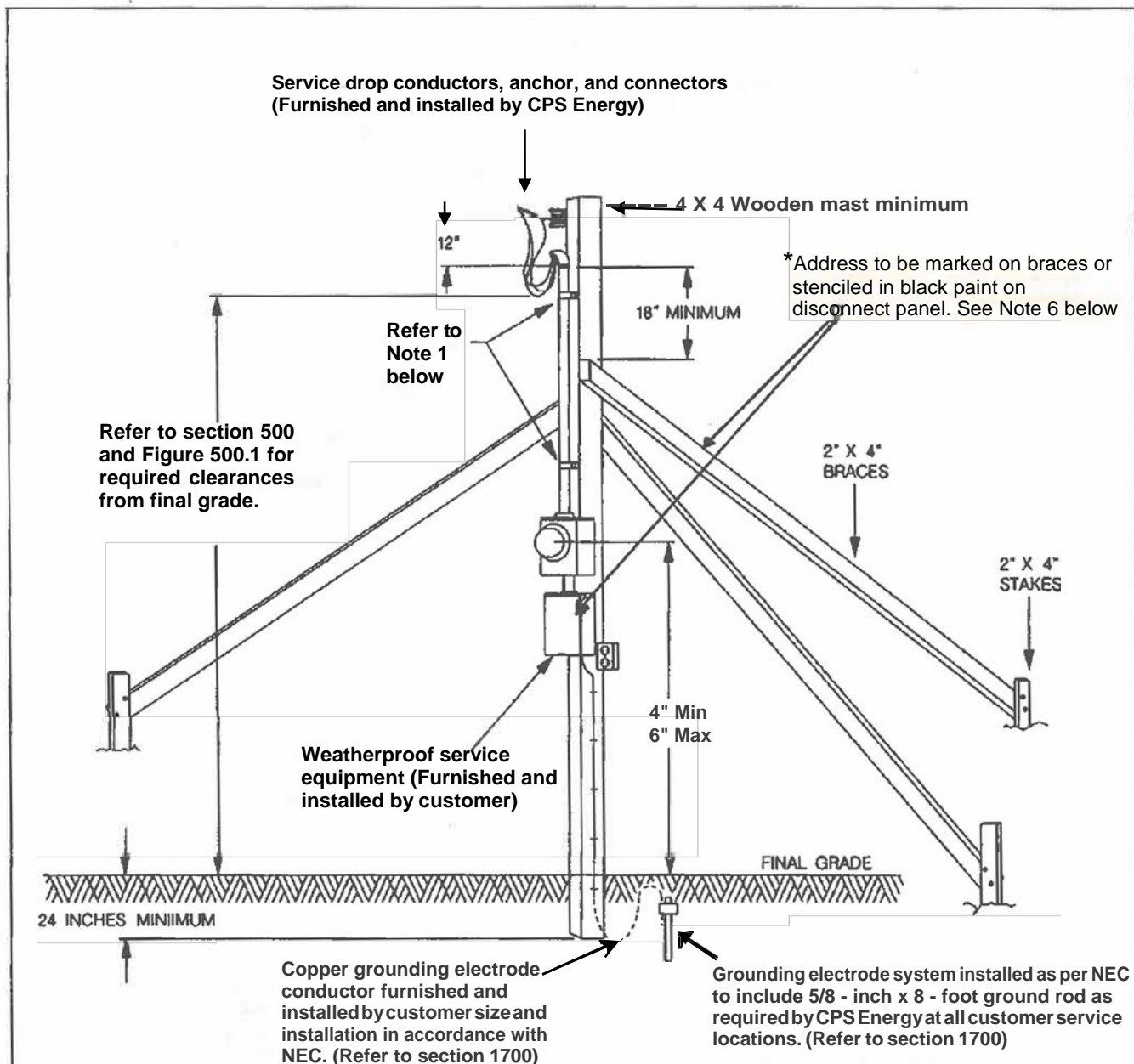

Notes

1. Service raceway shall be supported with 2-hole straps attached with screws and installed within 6 - 12 inches of service head and of meter enclosure.
2. 125 - ampere meter socket with 1 1/4 inch hub furnished, installed, and wired by customer. Refer to figure 1800.1.
3. Service raceway shall be furnished and installed by customer. Raceway shall be EMT, RMC, or IMC. Minimum sizes of service raceway is 1 1/4 inch.
4. Customer shall construct the temporary service installation as shown above and maintain it in a safe condition throughout its period of use. CPS Energy reserves the right to disconnect damaged or unsafe TMLs.
5. The temporary service installation must be identified with a proper service address before CPS Energy will connect and install a meter.
6. *Street number with #T should be stenciled in black paint on disconnect panel or full address with #T should be marked on braces.
7. Make sure tripod is secure and not blocking a power source.

CPS ENERGY
Customer Provides Trenching & Conduit (Residential Electric Only)

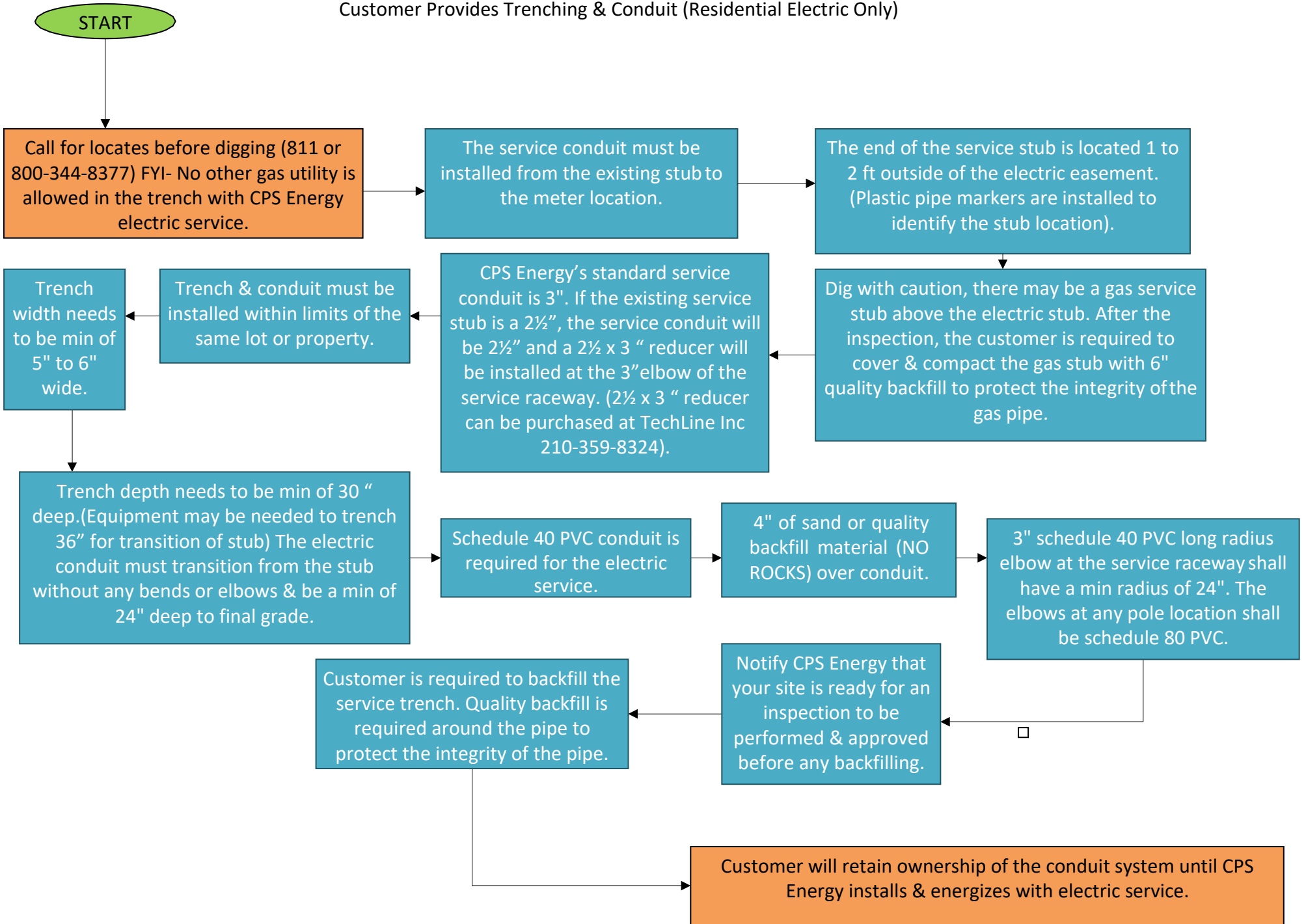

CPS ENERGY
Customer Provides Trenching & Conduit (Residential Gas & Electric)

