

CPS ENERGY AGREEMENT FOR JOINT TRENCHING

This agreement establishes the terms and conditions under which the City of San Antonio, Texas, acting by and through the San Antonio City Public Service Board d/b/a CPS Energy (“CPS Energy”), a municipal utility of the City of San Antonio, may grant access to certain underground trenches to ____, a corporation of the state of _____ (“Joint Trencher”) for the installation by Joint Trencher of its conduits, ducts, and facilities in such trenches (the “Agreement”), with such agreement to be effective as of the date of execution by the last signatory hereto (the “Effective Date”). CPS Energy and Joint Trencher are collectively referred to herein as the “Parties” and sometimes individually referred to herein as a “Party.”

Recitals

- A. CPS Energy has a need from time to time to construct trenches in order to place its electric utility facilities underground; and
- B. Joint Trencher has a need from time to time to place communications conduits, ducts, and other facilities underground; and
- C. CPS Energy is willing to allow Joint Trencher to place its communications conduits, ducts, and other facilities into CPS Energy trenches, provided that Joint Trencher is responsible for the design of its facilities, construction coordination with other entities regarding installation of its facilities, and making upfront payment of construction costs where applicable; and
- D. CPS Energy may refuse, on a non-discriminatory basis, to authorize such joint trenching where there is insufficient capacity or for reasons relating to safety, reliability, generally applicable engineering purposes, or any other Applicable Engineering Standards, in accordance with the terms and conditions of the CPS Energy Pole Attachment Standards and consistent with the duties outlined in this Agreement;

Therefore, in consideration of the foregoing recitals and of the mutual covenants, terms and conditions, remunerations, and other rights and obligations provided in this Agreement, the Parties agree as follows:

Article 1. Definitions

For the purposes of this Agreement, the following terms, phrases, words, and their derivations, shall have the meaning set forth in this Article, unless more specifically defined within another provision of this Agreement or in the Pole Attachment Standards. When not inconsistent with the context, words used in the present tense include the future tense, words in the plural number include the singular number, and words in the singular number include the plural number. The words “shall” and “will” are mandatory, and the word “may” is permissive. The word “or” includes “and,” unless the context indicates otherwise. Words not defined shall be given their common and ordinary meaning. Capitalized terms not listed in this Article 1 shall have the meaning given them in the Pole Attachments Standards.

- 1.1 **Applicable Engineering Standards** has the same meaning as in the Pole Attachment Standards.
- 1.2 **Attaching Entity** has the same meaning as in the Pole Attaching Standards.
- 1.3 **Civic Authority** means the City or any another governmental entity with authority over a Civic Project.
- 1.4 **Civic Project** means any specific project that requires adjustments of CPS Energy Poles, Streetlight Poles, or other CPS Energy Facilities to accommodate federal, state, city, or county roadway reconstruction/widening, drainage improvements, or other type of civic improvement project (reimbursable to CPS Energy or not) within the Public Right of Way.
- 1.5 **Commercial Joint Trench** means a trench excavated by CPS Energy in relation to a Commercial Underground Project for installation of its conduits, duct systems, and electrical and gas facilities which is offered to one or more Attaching Entities to relocate their existing aerial facilities by installing communications conduits and duct bank systems within CPS Energy's trench.
- 1.6 **Commercial Undergrounding Project** means a construction project undertaken by a Civic Authority, Private Developer, or CPS Energy, in which CPS Energy relocates its existing aerial non-residential electric facilities (including mixed-use facilities) to an underground trench.
- 1.7 **Developer's Engineer** means a Developer's designated engineer for purposes of reviewing and coordinating Residential Underground Projects.
- 1.8 **Developer's Representative** means a Developer's designated representative for purposes of coordinating Residential Underground Projects.
- 1.9 **Final Design** means the final engineering design documents and plans adopted by CPS Energy outlining the routing plan and specifications for the installation of all facilities to be located within a Joint Trench for a specific Residential or Commercial Underground Project.
- 1.10 **Joint Trencher's Design** means the engineering design documents outlining the routing plan and specifications for the installation of Joint Trencher's facilities in a Joint Trench for each specific Residential or Commercial Underground Project.
- 1.11 **Notice of Commercial Underground Project** has the meaning given in Section 4.1.1.
- 1.12 **Pole** has the same meaning as in the Pole Attachment Standards.

- 1.13 **Pole Attachment Standards (or Standards)** means the “CPS Energy Pole Attachment Standards” with an initial effective date of August 1, 2016, and as amended from time to time.
- 1.14 **Pre-Construction Meeting** means a meeting convened by CPS Energy or a Developer to confirm the Final Design and coordinate the construction schedule and process for a given Underground Project.
- 1.15 **Preliminary Design** means the initial engineering design documents and plans proposed by CPS Energy outlining the routing plan and specifications for the installation of facilities to be located within a Joint Trench for a specific Residential or Commercial Underground Project.
- 1.16 **Preliminary Design Meeting** means the initial meeting convened by CPS Energy or a Developer to communicate the joint trench planning and design process to Joint Trenchers for a given Underground Project.
- 1.17 **Private Developer (or Developer)** means a private individual or private entity undertaking a Private Development Project.
- 1.18 **Private Development Project** means any specific project that requires adjustments of or changes to CPS Energy Poles, Streetlight Poles, or other CPS Energy Facilities, to accommodate a Private Developer’s improvement project (whether reimbursable to CPS Energy or not).
- 1.19 **Residential Joint Trench** means a trench originally excavated by CPS Energy in relation to a Residential Underground Project for installation of its conduits, duct systems, and electrical and gas facilities which is offered to one or more entities for expansion to contain conduit and duct banks systems owned and maintained by more than one entity.
- 1.20 **Residential Joint Trench Service Request for Billing (or “Invoice”)** means the Invoice sent by CPS Energy in accordance with the CPS Energy Joint Trenching rates set out in Appendix A. An example of the Invoice is attached as Appendix B.
- 1.21 **Residential Joint Trench Table** means the table which identifies the actual number of linear feet that Joint Trencher’s facilities occupy in the Residential Joint Trench per the approved Joint Trencher’s design. An example of the Table is attached as Appendix C.
- 1.22 **Residential Undergrounding Project** means any specific project that requires communications conduits and duct bank systems within CPS Energy’s trenches designed to accommodate CPS Energy residential electric facilities.
- 1.23 **Underground Project Inspector** means a CPS Energy inspector charged with inspecting the installation of Joint Trencher’s facilities in a Joint Trench applicable to a Residential

Underground Project or a Commercial Joint Trench applicable to a Commercial Underground Project following the installation of such facilities.

1.24 Underground Residential Distribution Diagrams means the diagrams attached as Appendix D.

Article 2. Scope of Agreement

- 2.1 Subject to safety, reliability, and applicable engineering considerations, CPS Energy shall grant a non-exclusive license to Joint Trencher to access a Joint Trench or Commercial Joint Trench, as appropriate, to accommodate Joint Trencher's conduit, duct system, and communications facilities. CPS Energy may grant access to its trenches to more than one entity subject to the notice requirements provided in this Agreement.
- 2.2 Access to a Joint Trench under this Agreement shall be contingent of Joint Trencher's compliance with the following requirements:
 - 2.2.1 Timely notice of decision to install facilities in an available trench to CPS Energy or the general contractor, or other designated representative, for the appropriate construction project within the time frames provided herein;
 - 2.2.2 Coordination with the general contractor, or other designated representative, for the appropriate construction project, CPS Energy or its excavation contractor, and any other third-parties regarding the accommodation of Joint Trencher's facilities in an available trench;
 - 2.2.3 Timely completion and delivery of the engineering design documents necessary to accommodate Joint Trencher's facilities in an available trench;
 - 2.2.4 Upfront payment to general contractor, or other designated representative, or CPS Energy or its excavation contractor, as appropriate, of the construction cost to accommodate Joint Trencher's facilities in an available trench; and
 - 2.2.5 Timely installation of Joint Trencher's facilities in an available trench within the construction time frames established herein for the construction project.
 - 2.2.6 Compliance with all other applicable requirements of established herein.
- 2.3 This Agreement shall apply to the excavation activities and trenching functions performed by CPS Energy or its contractor(s) for:
 - 2.3.1 The installation of CPS Energy's primary and secondary electric facilities, and gas facilities as appropriate, in residential subdivisions as set out in the Residential Joint Trench provisions of Article 3; or

- 2.3.2 The relocation from aerial to underground of CPS Energy's non-residential electric facilities (including in mixed-use developments) as set out in the Commercial Joint Trench provisions of Article 4.
- 2.4 This Agreement is not applicable to service trenching.
- 2.5 This Agreement establishes the requirements under which Joint Trencher may gain access to an available trench with CPS Energy's consent that CPS Energy excavates for the underground installation of its facilities.
- 2.6 This Agreement is subject to the requirements of the Pole Attachment Standards, which may be amended from time to time.
- 2.7 Any use, operation, installation, maintenance activity, or removal function on the part of Joint Trencher in relation to its facilities in a CPS Energy trench shall be consistent with all Applicable Engineering Standards and all applicable federal, state, or local laws, regulations, and policies.
- 2.7.1 Examples of CPS Energy Residential Joint Trench installations are found in the Residential Underground Distribution Diagrams attached in Appendix D.
- 2.8 Joint Trencher may locate and maintain its ducts and conduits within a CPS Energy available trench and shall be solely responsible for obtaining and maintaining at its own cost, and providing to CPS Energy at its request, all requisite public and private authorizations, permits, and easements to occupy and operate its facilities within the Joint Trench.
- 2.9 A Joint Trencher's access to a CPS Energy available trench pursuant to this Agreement shall not convey, or be deemed to convey, any right or authorization to occupy or use any CPS Energy ducts or conduits within the trench.
- 2.10 CPS Energy shall excavate a trench to the depth necessary to accommodate its electrical and gas facilities, as applicable. Where Joint Trencher is granted access to an available trench for the installation of its conduits, duct systems, and facilities, Joint Trencher shall be responsible for the additional cost required to accommodate such facilities in the trench, including expanding the width or depth of a standard trench if necessary.
- 2.11 CPS Energy's prior consent is necessary to accommodate any Joint Trencher's oversized cables or conduits, or multiple cables or conduits. Joint Trencher shall not utilize any special excavation or trenching equipment in any available trench. All enlargements of a trench shall be undertaken by the qualified general contractor for a specific project or CPS Energy or its excavation contractor, as appropriate, pursuant to pre-approved engineering design documents and following receipt of the upfront construction cost payment.

- 2.12 Joint Trencher may participate in any trench segment along the length of an available trench excavated to meet the requirements for the installation of CPS Energy's facilities. Any extension or deviation of a trench segment outside of CPS Energy's trenching requirements must be approved by CPS Energy or the general contractor for the applicable construction project and shall be constructed at the sole cost of Joint Trencher. Any boring necessary to connect to an available trench will be the responsibility of the participating Joint Trencher. Joint Trencher will be responsible for placing its conduits, duct systems, and cables in a configuration consistent with the appropriate technical appendices to this Agreement with the electric conduits always at the bottom of the trench.

Article 3. Residential Joint Trench Agreement Requirements

The following terms and conditions shall govern a Joint Trencher's use of a CPS Energy Residential Joint Trench.

3.1 Residential Joint Trench Process and Requirements

- 3.1.1 Upon receipt of notification of a Residential Undergrounding Project initiated by CPS Energy, or a Private Developer, Joint Trencher shall notify CPS Energy or the Private Developer, as applicable, of its interest in participating in the Residential Undergrounding Project within the time frame specified by CPS Energy or the Project Developer.
- 3.1.2 The role and responsibility of CPS Energy under this Agreement with respect to Private Development Residential Undergrounding Projects is expressly limited to the design of CPS Energy infrastructure and transformers, including performing any required inspections, and obtaining permits for CPS Energy work.
- 3.1.2.1 For a Private Developer Project, CPS Energy shall provide the Private Developer, the Developer's Engineer, and/or the Developer's Representative, as appropriate, an electronic or hard copy of CPS Energy's Preliminary Design before or after the Preliminary Design Meeting that CPS Energy holds for each Residential Undergrounding Project. Joint Trencher shall be responsible for obtaining a copy of the Preliminary Design from the Developer for Joint Trencher's use in developing the routing plan for Joint Trencher facilities for each specific Residential Underground Project.
- 3.1.2.2 Prior to holding the Pre-construction Meeting for each Residential Underground Project, CPS Energy shall provide the Private Developer an electronic copy of CPS Energy's Final Design incorporating its electrical and gas facilities. Joint Trencher shall be responsible for obtaining a copy of the Final Design from the Developer, the Developer's Engineer, or the Developer's Representative, as applicable.

- 3.1.3 Joint Trencher will be subject to the following process to request access to a Residential Joint Trench for any Residential Underground Project:
 - 3.1.3.1 Joint Trencher shall be responsible for attending all design meetings associated with the Residential underground project. Within thirty (30) business days of CPS Energy's delivery of its Preliminary Design to the Developer, Joint Trencher shall provide CPS Energy its Joint Trencher's Design for incorporating its facilities into the Residential Joint Trench and identify the number of trench feet that the facilities will occupy.
 - 3.1.3.2 Within twenty (20) business days of receiving Joint Trencher's Design, CPS Energy will review the design documents for approval and provide Joint Trencher notice of the following:
 - 3.1.3.2.1 Approval or rejection of proposed engineering design;
 - 3.1.3.2.2 If the request is approved, an Invoice for access to the Residential Joint Trench based on the requested trench footage identified in Joint Trencher's Design (see example of Invoice in Appendix B); and
 - 3.1.3.2.3 A request to proceed with construction by making payment to cover the appropriate share of Joint Trencher's construction cost.
 - 3.1.3.3 Joint Trencher shall be responsible to make full payment of the CPS Energy Invoice for access to the Residential Joint Trench at least ten (10) business days prior to the Pre-construction meeting. The Invoice shall be calculated at the CPS Energy rates published at the time of Invoice.
 - 3.1.3.4 If CPS Energy rejects Joint Trencher's Design it shall explain the reason(s) for rejecting the proposed installation. If Joint Trencher continues to seek access to the Residential Joint Trench, within five (5) business days of receiving the rejection notice, Joint Trencher shall provide CPS Energy a revised version of its Joint Trencher's Design addressing the reason(s) for the initial rejection. CPS Energy shall review the revised version of Joint Trencher's Design pursuant to Section 3.1.3.2 and Joint Trencher shall be subject to the process described therein.
- 3.1.4 For any Residential Underground Project that is not being constructed (i.e. Developer Install) by CPS Energy, Joint Trencher shall be solely responsible for conveying to the applicable Private Developer its desires to participate in the Residential Underground Project. Joint Trencher shall also be solely responsible for making arrangements for cost reimbursement, if any, from the applicable Private Developer

\associated with the installation of its facilities.

- 3.1.5 In no event will CPS Energy be obligated to pay for any of Joint Trencher's costs associated with participating in a Residential Joint Trench, nor shall CPS Energy act as a collection agent on behalf of, or as an intermediary between, Joint Trencher and any third party, including any Private Developer. All such costs shall be the sole responsibility of Joint Trencher, and Joint Trencher shall make its own payment arrangements with the Private Developer, as applicable, and their respective contractors.
- 3.1.6 Any Joint Trencher that timely paid its Invoice to access the Residential Joint Trench shall participate in the Pre-construction Meeting for the applicable Residential Undergrounding Project. At the Pre-construction Meeting, Joint Trencher shall identify any additional proposed revisions in the number and size of conduits per trench segment included in the Final Design. Any deviations from the approved design agreement will be subject to additional cost. Such proposed revisions to Joint Trencher's Design shall be reviewed pursuant to Section 3.1.2.2. If no revision to the Final Design is proposed, Joint Trencher shall sign off on the Final Design in relation to its facilities.
- 3.1.7 All Joint Trencher(s), participating in the Residential Underground Project shall provide a copy of their final design to the foreman of the crew performing the trenching work on behalf of CPS Energy.
- 3.1.8 Joint Trencher shall have ten (10) business days prior to the start of CPS Energy's excavation and trenching operations in which to schedule the installation of Joint Trencher's facilities per the revised Final Design. Joint Trencher shall be responsible for coordinating the installation of its facilities in each segment of an open Residential Joint Trench and for monitoring progress of trenching operations on each specific Residential Underground Project. Beyond the ten (10) business days period for scheduling the installation of Joint Trencher's facilities, CPS Energy shall have no responsibility to notify Joint Trencher of the timing of each trench segment's open or closed status once trenching construction begins. It is the responsibility of the Joint Trencher(s) to coordinate with construction contractors and/or Developer concerning joint trench activities.
- 3.1.9 Once CPS Energy completes the installation of its electrical and prior to gas facilities being installed, if any, and its conduits to the specified depth, it will leave the Residential Joint Trench open for the installation of Joint Trencher's facilities. Joint Trenchers must begin installing their utility no later than 48 hours after CPS Energy, or representative, installs electrical facilities. If Joint Trencher fails to install its conduit within the agreed upon construction schedule, CPS Energy may, at its discretion, elect to backfill any portion of its excavation. Once the Residential Joint Trench is covered, Joint Trencher shall not remove the backfill to install its

facilities, without the written consent of CPS Energy.

- 3.1.10 CPS Energy construction foreman, or representative, will make additional 24-hour notifications each time trenching is re-started after construction delays due to material shortages or CPS Energy's deferral of work for any reason except normal off-work hours, weekends, and holidays. Same-day notification will be given to Joint Trencher to resume work delayed due to weather. Joint Trencher will be notified of any changes in plans or construction scheduling.
- 3.1.11 CPS Energy may elect not to leave any excavation open overnight for security and safety reasons.
- 3.1.12 Joint Trencher shall inspect and monitor all joint trench activities for each Residential Underground Project to ensure that its conduits, ducts, and other facilities have been installed as planned. Such inspection shall occur during the installation of Joint Trencher's conduits, ducts, and facilities in the trench or at any other time during the trenching/backfilling process. If any portion of the Residential Underground Project is not inspected by Joint Trencher, CPS Energy will treat the installation for that portion of the Residential Underground Project as having been inspected and accepted by Joint Trencher. Joint Trencher shall be solely responsible and liable for any rework, additional costs, or damages associated with Joint Trencher's failure to inspect any portion of a Residential Underground Project.
- 3.1.13 The Underground Project Inspector shall schedule an on-site meeting with Joint Trencher when all trenching operations are complete, but before the Residential Joint Trench is backfilled, to ensure Joint Trencher's facilities were installed as planned. Any discrepancies identified by Joint Trencher must be validated by the Underground Project Inspector in order to determine any necessary true-up to the Residential Joint Trench Table, which identifies the number of feet that Joint Trencher's facilities occupy in the Residential Joint Trench per the approved Joint Trencher's Design. Joint Trencher shall sign the Residential Joint Trench Table as acceptance of the joint trench footage covered by its facilities. If the Joint Trencher does not attend the on-site meeting the Underground Project Inspector's determination shall be final. If a discrepancy is verified by the Underground Project Inspector, the following process will apply:
 - 3.1.13.1 If the discrepancy shows that Joint Trencher's facilities actually occupy less feet of space in the Residential Joint Trench than the number of feet identified in the Residential Joint Trench Table, CPS Energy shall grant Joint Trencher a credit based on the number of feet overstated to be applied on the next Residential Underground Project in which Joint Trencher participates.

3.1.13.2 If the discrepancy shows that Joint Trencher's facilities actually occupy more feet of space in the Residential Joint Trench than the number of feet identified in the Residential Joint Trench Table, CPS Energy shall, within thirty (30) days of project completion, send an Invoice to Joint Trencher based on the number of feet understated.

3.1.14 Joint Trencher will stake its pedestal locations according to Applicable Engineering Standards before the start of construction for identification purposes only. A Residential Joint Trench will not include trenching or backfill for Joint Trencher's pedestal installations.

3.2 Residential Joint Trench Costs.

3.2.1 Joint Trencher shall pay CPS Energy for access to a Residential Joint Trench as specified in Appendix A to recovery actual costs that reflect pro-rata shares of trenching costs, on a per entity basis, to all entities participating in a Residential Underground Project. CPS Energy shall treat itself as one entity, regardless of whether it is installing electric facilities only or whether it is installing gas and electric facilities.

3.2.1.1 Invoices for Joint Trench costs will be subject to an additional administrative fee of \$25 per hour to recover CPS Energy's administrative costs of processing, invoicing, and related clerical work for managing the Joint Trench process.

3.2.2 CPS Energy may in its sole discretion adjust its rates from time to time, which rates shall become effective thirty (30) days after CPS Energy publishes the new rates on its website. Such new rates shall not apply to existing job in-progress.

3.2.3 Any invoice to rectify an undercount in the Residential Joint Trench Table as described in Section 3.1.13.2 is due and payable within thirty (30) days of invoice date. Payments made after thirty (30) days will be assessed a two percent (2%) per month interest charge.

3.2.4 If Joint Trencher fails to pay costs as prescribed by Section 3.2.3 above, CPS Energy has the right to immediately suspend Joint Trencher's rights to participate in any future joint trench arrangement under this Agreement. CPS Energy may also undertake any other available legal enforcement rights until payments of such costs are made to CPS Energy.

Article 4. Commercial Joint Trench Agreement Requirements

4.1 The following terms and conditions shall govern a Joint Trencher's use of a CPS Energy Commercial Joint Trench.

- 4.1.1 Upon notification from CPS Energy, a Civic Authority, or a Private Developer of a pending Commercial Underground Project that will require CPS Energy to relocate its existing non-residential electric facilities (including mixed-use development facilities) to underground conduits, manholes, or duct systems (“**Notice of Commercial Underground Project**”), Joint Trencher, that is also an Attaching Entity with existing aerial facilities on Poles subject to relocation, shall notify CPS Energy of its interest in participating in the Commercial Joint Trench. Unless otherwise specified, Joint Trencher shall provide such notice to CPS Energy within thirty (30) days of receiving the Notice of Commercial Underground Project, but in no event later than thirty (30) days prior to the beginning of construction.
- 4.1.2 Joint Trencher shall be responsible for attending all design meetings associated with the Commercial Underground Project and shall coordinate with the applicable party (Civic Authority, Private Developer, or CPS Energy) that is managing the project. CPS Energy shall endeavor, but shall not be required, to provide Joint Trencher an electronic or hard copy of CPS Energy’s Preliminary Design for the proposed Commercial Joint Trench before or after the Commercial Underground Project’s Preliminary Design Meeting.
- 4.1.3 For any Commercial Underground Project that is not being initiated or managed by CPS Energy, Joint Trencher shall be solely responsible for conveying to the applicable Civic Authority or Private Developer its desires to participate in the Commercial Underground Project. Joint Trencher shall also be solely responsible for making arrangements for cost reimbursement, if any, from the applicable Civic Authority or Private Developer associated with the relocation of its facilities.
- 4.1.4 Joint Trencher shall be solely responsible for coordinating with the applicable Civic Project’s or the Private Development Project’s manager and construction design contractor the design, specifications, costs, and construction schedule of the undergrounding of Joint Trencher’s facilities, including the design of proposed conduits and duct bank systems. Joint Trencher shall enter into any necessary agreements with the Civic Authority or Private Developer for any available reimbursement at its sole and complete discretion.
- 4.1.5 Consistent with the Commercial Underground Project’s design and specifications and all Applicable Engineering Standards, CPS Energy will allow Joint Trencher to relocate its existing aerial facilities into a Commercial Joint Trench along with CPS Energy’s electrical facilities, provided that all such joint trenching operations shall be at no additional cost to CPS Energy and shall be consistent with this Agreement and the Pole Attachment Standards.

- 4.1.6 In no event will CPS Energy be obligated to pay for any of Joint Trencher's costs associated with participating in a Commercial Joint Trench, nor shall CPS Energy act as a collection agent on behalf of, or as an intermediary between, Joint Trencher and any third party, including any Civic Authority or Private Developer. All such costs shall be the sole responsibility of Joint Trencher, and Joint Trencher shall make its own payment arrangements with the Civic Authority or Private Developer, as applicable, and their respective contractors.
- 4.1.7 At least sixty (60) days prior to the actual start of construction of the Commercial Joint Trench, Joint Trencher shall provide CPS Energy electronic and hard copies of Joint Trencher's Design of the proposed facilities to be installed within the Commercial Joint Trench, including the number and size of ducts, conduits, and other facilities that Joint Trencher wishes to install in each trench segment.
- 4.1.8 CPS Energy shall revise the Preliminary Design to incorporate the approved Joint Trencher's Design into the Final Design of facilities to be accommodated in the Commercial Joint Trench and shall provide a copy to the foreman of the crew performing the trenching work on behalf of CPS Energy.
- 4.1.9 Joint Trencher shall have ten (10) business days prior to the start of CPS Energy's excavation and trenching operations in which to schedule the installation of Joint Trencher's facilities per the Final Design. Joint Trencher shall be responsible for coordinating the installation of its facilities in each segment of an open Commercial Joint Trench and for monitoring progress of trenching operations on each specific Commercial Underground Project. Beyond the ten (10) business days period for scheduling the installation of Joint Trencher's facilities, CPS Energy shall have no responsibility to notify Joint Trencher of the timing of each trench segment's open or closed status once trenching construction begins.
- 4.1.10 Once CPS Energy completes the installation of its electrical facilities and the concrete casting of its conduits to the specified depth, it will leave the Commercial Joint Trench open for the installation of Joint Trencher's facilities. If Joint Trencher fails to install its conduit within the agreed upon construction schedule, CPS Energy may, at its discretion, elect to backfill any portion of its excavation. Once the Commercial Joint Trench is covered, Joint Trencher shall not remove the backfill to install its facilities.
- 4.1.11 CPS Energy will make additional 24-hour notifications each time trenching is re-started after construction delays due to CPS Energy material shortages or deferment of work for any reason except normal off work hours, weekends, and holidays. Same-day notification will be given Joint Trencher to resume work delayed due to weather. Joint Trencher will be notified of any changes in plans or construction scheduling.

- 4.1.12 CPS Energy may elect not to leave any excavation open overnight for security and safety reasons.
- 4.1.13 Joint Trencher shall inspect and monitor all joint trench activities for each Commercial Underground Project to ensure that its conduits have been installed within the Commercial Joint Trench as planned. Such inspection shall occur during the installation of Joint Trencher's conduits in the trench or at any other time during the trenching/backfilling process. If any portion of the Commercial Underground Project is not inspected by Joint Trencher, the conduit installation for that portion of the Commercial Underground Project will be treated as having been inspected and accepted. Joint Trencher shall be responsible for any rework and additional costs associated with Joint Trencher's failure to inspect any portion of a Commercial Underground Project.
- 4.1.14 Joint Trencher will stake its pedestal locations according to Applicable Engineering Standards before the start of construction for identification purposes only. A Commercial Joint Trench will not include trenching or backfill for Joint Trencher's pedestal installations.

Article 5. Coordination.

All work, excluding work not being managed by CPS Energy (i.e. Developer Install or Customer Installation) to be performed as required by this Agreement shall be coordinated by CPS Energy through its designated representative and by Joint Trencher through its engineering coordinator or designated representative, and if applicable, the designated representatives of the Civic Authority or Private Developer.

Article 6. Notice.

All notices required under or regarding this Agreement will be in writing and will be considered properly given if delivered personally, mailed via registered or certified mail (return receipt requested and postage prepaid), email, or sent by courier (confirmed by receipt) addressed to the parties' address designated below. Notice provided by email to LegalNotices@cpsenergy.com shall not, however, be valid unless receipt of such email is confirmed by CPS Energy via return email or otherwise.

Notice to CPS Energy:

CPS Energy
Attn: General Counsel
P.O. Box 1771
San Antonio, Texas 78296
LegalNotices@cpsenergy.com

Notice to Joint Trencher:

Article 7. Operation and Maintenance of Jointly Installed Facilities.

- 7.1 Each Party shall be responsible for its own excavation for routine maintenance.
- 7.2 In the event one of the Parties damages the underground facilities of any other entity, including the other Party, while excavating or performing maintenance, the Party that caused the damages shall notify the owner of the damaged facilities and shall pay the costs of repairing the damaged facilities.
- 7.2.1 A Party that damages the underground facilities of another entity, including the other Party, shall make repairs or hire a third party to make repairs of the damaged facilities unless authorized in writing by the owner of such underground facilities.
- 7.2.2 The Party that caused the damage while performing repairs or maintenance may leave the excavation open for the entity with the damaged facilities to have its facilities repaired. If the Party does not leave the excavation open for the owner of the damaged facilities, it shall be the responsibility of the owner of the damaged facilities to reopen, close, and return the construction site to standard acceptable finished condition. The costs of reopening, closing, and restoration to finished condition may be included in costs of repairs billed for damages by the owner of the damaged facilities to the Party that caused the damages.
- 7.3 Emergency Repairs.

It may or may not be practical under specific circumstances for trench-sharing entities to make repairs and/or to do work simultaneously in an emergency, as all sharing entities may not be damaged or affected in the same way by the emergency conditions. When more than one entity is affected, the following sequence of work will be followed in the interest of safety:

- 7.3.1 Electric circuits will be cleared by switching or whatever expedient means are available; and
- 7.3.2 Leaking gas will be stopped with valves or temporary or permanent repairs.

Once potentially hazardous conditions have been removed, the following procedure will be used, where applicable. The entity making the initial excavation shall complete its repairs before the next entity starts its repairs. The last entity to complete repairs shall have the responsibility of returning the site to standard acceptable condition.

7.4 Charges and Collections for Damages.

Where entities, some or all, engaged in a Joint Trench activity suffer damage by a means other than work by one of the entities, each participating entity shall be responsible for billing for and collection of its own costs. Any details related to damage and cause shall be available and freely exchanged among all entities.

Article 8. Assignability and Termination.

This Agreement is not assignable without the prior written consent of the other Party, which consent shall not be unreasonably denied or delayed. Either Party may terminate the Agreement giving the other Party thirty (30) days written notice, the effect of which shall be to terminate the Party's ability to participate in future Joint Trenching. Any and each Underground Project in progress at the time of the notice of termination shall be completed under the terms herein.

Article 9. Limitation of Liability.

- 9.1 CPS Energy reserves to itself the right to undertake and conduct any and all trenching that CPS Energy makes in conjunction with the installation of each of its facilities in each Residential or Commercial Underground Project.
- 9.2 AS A MATERIAL PART OF THE CONSIDERATION OF THIS AGREEMENT, JOINT TRENCHER TAKES AND ACCEPTS ANY AND ALL TRENCHES CPS ENERGY CONSTRUCTS IN THE CONDITION IN WHICH JOINT TRENCHER FINDS THE CPS ENERGY TRENCH, WITH ANY AND ALL LATENT AND PATENT DEFECTS AND WITH NO EXPRESS OR IMPLIED WARRANTIES BY CPS ENERGY OF MERCHANTABILITY, FITNESS, SUITABILITY OR THAT THE TRENCHES ARE FIT FOR ANY PARTICULAR PURPOSE. JOINT TRENCHER ACKNOWLEDGES THAT IT IS NOT RELYING UPON ANY REPRESENTATION, STATEMENT, OR OTHER ASSERTION WITH RESPECT TO THE CONDITION OF ANY CPS ENERGY TRENCH, BUT IS RELYING UPON ITS EXAMINATION OF THE CPS ENERGY TRENCH AT THE TIME OF ANY GIVEN RESIDENTIAL OR COMMERCIAL UNDERGROUND PROJECT. NEITHER CPS ENERGY NOR OTHER JOINT TRENCHER SHALL BE LIABLE TO JOINT TRENCHER, ITS CUSTOMERS, OR ANYONE ELSE FOR ANY INTERRUPTION TO SERVICE OF JOINT TRENCHER OR ANY INTERFERENCE WITH THE OPERATION OF THE FACILITIES OF JOINT TRENCHER.
- 9.3 NEITHER PARTY TO THIS AGREEMENT (NOR ITS EMPLOYEES, AGENTS, SUPPLIERS OR AFFILIATES) SHALL BE LIABLE TO THE OTHER FOR ANY INDIRECT, SPECIAL, INCIDENTAL, OR CONSEQUENTIAL DAMAGES SUFFERED BY THE OTHER PARTY, SUCH AS, BUT NOT LIMITED TO, LOSS OF ANY ANTICIPATED PROFITS, CLAIMS OF CUSTOMERS, LOSS OF REVENUE, LOSS OF

USE OF THE FACILITIES OR SYSTEM OF JOINT TRENCHER, COST OF CAPITAL, INCREASED EXPENSES OR OPERATION OF OTHER FACILITIES, OR COST OF REPLACEMENT EQUIPMENT, FACILITIES OR POWER, ARISING IN CONNECTION WITH THE AGREEMENT, EVEN IF THE PARTY HAS BEEN ADVISED OR SHOULD BE AWARE OF THE POSSIBILITY OF SUCH DAMAGES. NOTHING CONTAINED IN THE FOREGOING IS INTENDED IN ANY WAY TO LIMIT THE MAXIMUM RECOVERY AVAILABLE TO CPS ENERGY TO THE EXTENT IT IS COVERED UNDER THE APPLICABLE POLICIES OF INSURANCE STIPULATED IN "ADDENDUM A" TITLED "MINIMUM INSURANCE REQUIREMENTS."

Article 10. Indemnification.

10.1 Joint Trencher, and any agent, contractor or subcontractor of Joint Trencher, shall defend, indemnify, and hold harmless (collectively "Indemnification") CPS Energy and its officials, officers, board members, council members, commissioners, representatives, employees, agents, and contractors, against any and all claims, demands, liability, costs, damages (including punitive, special, indirect, or consequential), fines, taxes, special charges by others, penalties, payments (including payments made by CPS Energy under any Workers' Compensation Laws or under any plan for employees' disability and death benefits), and expenses (including reasonable attorney's fees of CPS Energy and all other costs and expenses of litigation) ("Covered Claims") arising in any way, including any act, omission, failure, negligence or willful misconduct, in connection with the construction, maintenance, repair, presence, use, relocation, transfer, removal or operation by Joint Trencher, or by Joint Trencher's officers, directors, employees, agents, or contractors, of Joint Trencher's facilities, except to the extent of CPS Energy's negligence or willful misconduct giving rise to such Covered Claims. To the extent that any Covered Claim arises from the concurrent conduct of CPS Energy, Joint Trencher, and/or any third party, it is expressly agreed that each party's obligations of Indemnification under this section shall be effective only to the extent of each party's pro rata share of liability. **All indemnities contained in this Agreement shall survive its termination.** Such Covered Claims include, but are not limited to, the following:

10.1.1 Cost of work performed by CPS Energy that was necessitated by Joint Trencher's failure, or the failure of Joint Trencher's officers, directors, employees, agents, or contractors, to install, maintain, use, transfer, or remove Joint Trencher's facilities in accordance with the requirements and specifications of this Agreement, or from any other work this Agreement authorizes CPS Energy to perform on Joint Trencher's behalf;

10.1.2 Claims for damage to or destruction of property or injury to or death of any person or persons that arise out of or are caused by the erection, installation, maintenance, presence, operation, use, rearrangement or removal of or from CPS Energy trenches of the facilities of Joint Trencher or by the proximity of the

facilities of Joint Trencher to CPS Energy Facilities or the facilities of other entities or by any act, omission, or negligence of Joint Trencher or its contractors, agents, and employees on or in the vicinity of CPS Energy Facilities, Joint Trencher's facilities, or other entities' facilities;

- 10.1.3 Liabilities incurred as a result of Joint Trencher's violation, or a violation by Joint Trencher's officers, directors, employees, agents, or contractors, of any law, rule, or regulation of the United States, State of Texas or any other governmental entity or administrative agency;
- 10.1.4 Claims of governmental bodies, property owners, or others alleging that Joint Trencher does not have sufficient right or authority for placing and maintaining the facilities of Joint Trencher at the locations of trenches owned by CPS Energy;
- 10.1.5 Claims for taxes or special charges by others, which arise directly or indirectly from the construction, maintenance, or operation of the facilities of Joint Trencher and are payable pursuant to federal, state, or local regulation, statute, or other requirement; and/or
- 10.1.6 Claims caused by or relating in any manner to a breach of this Agreement or a failure to follow the terms of this Agreement by Joint Trencher or its agents and employees or by Joint Trencher's contractors or their agents and employees.

10.2 Procedure for Indemnification.

- 10.2.1 CPS Energy shall give prompt notice to Joint Trencher of any claim or threatened claim, specifying the factual basis for such claim and the amount of the claim. If the claim relates to an action, suit, or proceeding filed by a third party against CPS Energy, CPS Energy shall give the written notice to Joint Trencher no later than ten (10) calendar days after CPS Energy receives written notice of the action, suit, or proceeding.
- 10.2.2 CPS Energy's failure to give the required notice will not relieve Joint Trencher from its obligation to indemnify CPS Energy unless and to the extent Joint Trencher is materially prejudiced by such failure.
- 10.2.3 Joint Trencher will have the right at any time, by written notice to CPS Energy, to participate in or assume control of the defense of the claim with counsel of its choice, which counsel must be reasonably acceptable to CPS Energy. CPS Energy agrees to cooperate fully with Joint Trencher. If Joint Trencher so assumes control of the defense of any third-party claim, CPS Energy shall have the right to participate in the defense at its own expense. If Joint Trencher does not so assume control or otherwise participate in the defense of any third-party claim, Joint Trencher shall be bound by the results obtained by CPS Energy with respect to the

claim.

- 10.2.4 If Joint Trencher assumes the defense of a third-party claim as described above, then in no event will CPS Energy admit any liability with respect to, or settle, compromise, or discharge, any third party-claim without Joint Trencher's prior written consent, and CPS Energy will agree to any settlement, compromise, or discharge of any third-party claim which Joint Trencher may recommend which releases CPS Energy completely from such claim.

Article 11. Environmental Hazards.

- 11.1 Joint Trencher represents and warrants that its use of CPS Energy's trenches will not generate any Hazardous Substances, that it will not store or dispose on or about CPS Energy's trenches or transport to CPS Energy's trenches any Hazardous Substances, and that the facilities of Joint Trencher will not constitute or contain and will not generate any Hazardous Substance in violation of federal, state, or local law now or hereafter in effect, including any amendments.
- 11.2 Joint Trencher further represents and warrants that in the event of breakage, leakage, incineration, or other disaster, Joint Trencher's facilities will not release such Hazardous Substances. Joint Trencher, and its agents, contractors, and subcontractors, shall defend, indemnify and hold harmless CPS Energy and its respective officials, officers, board members, council members, commissioners, representatives, employees, agents, and contractors against any and all liability, costs, damages, fines, taxes, special charges by others, penalties, punitive damages, expenses (including reasonable attorney's fees and all other costs and expenses of litigation) arising from or due to the release, threatened release, storage, or discovery of any Hazardous Substances on, under or adjacent to CPS Energy's trenches attributable to Joint Trencher's use of CPS Energy's trenches.
- 11.3 Should CPS Energy's trenches be declared to contain Hazardous Substances, CPS Energy, Joint Trencher, and all other entities shall share proportionately in the cost of disposal of said Hazardous Substances based on each entity's individual percentage use of same, provided, however, if the source or presence of the Hazardous Substance is solely attributable to any particular parties, such costs shall be borne solely by those parties.
- 11.4 "Hazardous Substance" shall be interpreted broadly to mean any substance or material designated or defined as hazardous or toxic waste, hazardous or toxic material, hazardous or toxic or radioactive substance, or other similar term by any federal, state, or local laws, regulations or rules now or hereafter in effect, including any amendments.

Article 12. Municipal Liability Limits.

No provision of this Agreement is intended, or shall be construed, to be a waiver for any purpose by CPS Energy of any applicable State limits on municipal liability. No indemnification

provision contained in this Agreement under which Joint Trencher indemnifies CPS Energy shall be construed in any way to limit any other indemnification provision contained in this Agreement.

Article 13. Attorney's Fees.

If either Party to this Agreement brings a successful action in a court of competent jurisdiction to enforce this Agreement, the Party non-prevailing shall pay the prevailing Party's reasonable attorney's fees.

Article 14. Insurance.

14.1 Minimum Insurance Requirements. Joint Trencher agrees to carry and keep insurance in full force during the term of the Agreement sufficient to fully protect CPS Energy from all damages, claims, suits and/or judgments including, but not limited to, errors, omissions, violations, fees and penalties caused or claimed to have been caused by, or in connection with the performance or failure to perform under the Agreement by Joint Trencher, Joint Trencher's agents or employees, a Joint Trencher subcontractor, or its agents or employees. Failure to meet and maintain minimum insurance requirements throughout the life of the Agreement shall constitute a default and grounds for termination. The minimum amount of insurance as required shall be in accordance with "Addendum A" titled "Minimum Insurance Requirements." Joint Trencher's insurance shall be primary to and non-contributory with any self-insurance and/or insurance maintained by CPS Energy. Unless otherwise required by CPS Energy in writing, certificates of insurance or copies of insurance policies and policy endorsements required under Addendum A may be remitted to InsuranceServices@cpsenergy.com.

14.2 Change in Minimum Insurance Requirements. Should the minimum insurance requirements of CPS Energy change, Joint Trencher shall be notified in writing and Joint Trencher shall have sixty (60) days to meet the new requirements.

Article 15. Miscellaneous

15.1 Independent Contractor. The Parties recognize that Joint Trencher is an independent entity and nothing within the Agreement shall be construed to create a joint venture, partnership, agency, or other employment relationship between the Parties, or as granting a franchise under federal or state law. All Joint Trencher employees, contractors, representatives, or agents shall be considered to be an employee of Joint Trencher only and will not be considered an agent or employee of CPS Energy for any purpose. Joint Trencher will be solely responsible for payment of all compensation owed to its employees, contractors, representatives, or agents, including all applicable federal, state and local employment taxes and will make deductions for all taxes and withholdings required by law. In no event will any Joint Trencher employee be eligible for or entitled to participate

in any of the employee benefit plans or similar programs of CPS Energy.

- 15.2 Waiver. The rights and remedies provided to each of the Parties herein shall be cumulative and in addition to any other rights and remedies provided by law or otherwise. Any failure in the exercise by either Party of its right to terminate the Agreement or to enforce any provision of the Agreement for default or violation by the other Party shall not prejudice such Party's rights of termination or enforcement for any further or other's default or violation or be deemed a waiver or forfeiture of those rights.
- 15.3 Applicable Law and Venue. The Agreement is performable in San Antonio, Bexar County, Texas, and is governed by the laws of the State of Texas. Exclusive venue for all actions under the Agreement shall be in the state courts of the State of Texas, Bexar County, Texas. CPS Energy's obligations pursuant to the Agreement are subject to Texas Government Code Chapter 1502.

CPS ENERGY

JOINT TRENCHER

Name: _____

Name: _____

Printed Name: _____

Printed Name: _____

Title: _____

Title: _____

Date: _____

Date: _____

APPENDIX A

Residential Joint Trench Rates (\$/Ft.) per Joint Trench Entity

Installation Type	CPS Energy Plus 1 Joint Trench	CPS Energy Plus 2 Joint Trench	CPS Energy Plus 3 Joint Trench	CPS Energy Plus 4 Joint Trench
Dirt Trench by Equipment	\$2.09 per ft.	\$1.39 per ft.	\$1.05 per ft.	\$0.84 per ft.
Dirt Trench by Hand	\$9.23 per ft.	\$6.15 per ft.	\$4.61 per ft.	\$3.69 per ft.
Rock Trench by Equipment	\$3.66 per ft.	\$2.44 per ft.	\$1.83 per ft.	\$1.46 per ft.
Rock Trench by Hand	\$20.02 per ft.	\$13.35 per ft.	\$10.01 per ft.	\$8.01 per ft.

Rates will also be subject to an additional administrative fee of \$25 per hour for invoicing and clerical work.

Notes:

- (1) CPS Energy is counted as one entity regardless of whether there is Gas in the trench or not.
- (2) All trench costs will be based on standard trench depth of 42". In cases where CPS Energy requires a trench depth of 48" to accommodate its Gas facilities, joint trench costs will still be based on 42" trench depth.
- (3) Assumes maximum of 2-3" conduits or equivalent per Joint Trench Entity (not including CPS Energy).
- (4) If additional trench depth is required to accommodate additional Joint Trench conduits, Joint Trench Entity causing additional depth shall be responsible for the additional trench cost.

APPENDIX B

Residential Joint Trench Service Request for Billing

[Bill To:]	JOINT TRENCH COMPANY NAME
[Customer No.]	123456789 / 123456789
[Billing Contact]	
[Street Address 1]	
[Street Address 2]	
[City, ST ZIP Code]	
[Phone]	
P.O. Joint - Trenching for	MARCH 2022

Joint-Trenching
Services
Request for Billing
E-0065-0000004

Description	WR#	Footage	Line Total
TOBEY HILL	12345678	1125	\$ 1,215.00
OVERLOOK AT MIDDLE CREEK UNIT 7	9101112	4058	\$ 2,729.12
HOOT OWL TRACT UNIT 1A PART 1	13141516	6448	\$ 4,293.04
HOOT OWL TRACT UNIT 1A PART 2	17181920	600	\$ 648.00
KENNEDY RANCH UNIT 2D	21222324	3704	\$ 3,532.16
LIBERTY HILL UNIT 12	25262728	6153	\$ 5,489.98
RIVER VALLEY UNIT 3B	29303132	3475	\$ 3,796.76
RILEY TRACT UNIT 2	33343536	3365	\$ 3,091.88
			-
			-

Billing requested by: CPS Energy Representative

Total to Invoice	\$ 24,796.94
------------------	--------------

APPENDIX C

Residential Joint Trench Table

MEARS																							
JOB NAME: <u>OVERLOOK AT MEDIO CREEK UNIT 7</u>																							
WR# <u>40369267</u>																							
SEG	CO	TF	T#	2"	4"	SEG	CO	TF	T#	2"	4"	SEG	CO	TF	T#	2"	4"	SEG	CO	TF	T#	2"	4"
FROM	1	TO	4			FROM	10	TO	9			FROM	15	TO	38			FROM	4	TO	23		
E	FT	50	D/R			E	FT	120	D/R			E	FT	25	D/R			E	FT	25	D/R		
	TW	50	2				TW	120	2				TW	25	1				TW	25	1		
	GV	N/A					GV	N/A					GV	N/A					GV	N/A			
	ATT	50	2				ATT	120	2				ATT	25	1				ATT	25	1		
FROM	2	TO	18			FROM	9	TO	8			FROM	15	TO	37			FROM	3	TO	22		
E	FT	165	D/R			E	FT	165	D/R			E	FT	25	D/R			E	FT	25	D/R		
	TW	165	2				TW	165	2				TW	25	1				TW	25	1		
	GV	N/A					GV	N/A					GV	N/A					GV	N/A			
	ATT	165	2				ATT	165	2				ATT	25	1				ATT	25	1		
FROM	18	TO	17			FROM	8	TO	7			FROM	14	TO	36			FROM		TO			
E	FT	80	D/R			E	FT	75	D/R			E	FT	25	D/R			E/G	FT		D/R		
	TW	80	2				TW	75	2				TW	25	1				TW				
	GV	N/A					GV	N/A					GV	N/A					GV				
	ATT	80	2				ATT	75	2				ATT	25	1				ATT				
FROM	17	TO	16			FROM	7	TO	6			FROM	13	TO	35			FROM		TO			
E	FT	177	D/R			E	FT	85	D/R			E	FT	25	D/R			E/G	FT		D/R		
	TW	177	2				TW	85	2				TW	25	1				TW				
	GV	N/A					GV	N/A					GV	N/A					GV				
	ATT	177	2				ATT	85	2				ATT	25	1				ATT				
FROM	16	TO	15			FROM	6	TO	5			FROM	12	TO	34			FROM		TO			
E	FT	80	D/R			E	FT	80	D/R			E	FT	25	D/R			E/G	FT		D/R		
	TW	80	2				TW	80	2				TW	25	1				TW				
	GV	N/A					GV	N/A					GV	N/A					GV				
	ATT	80	2				ATT	80	2				ATT	25	1				ATT				
FROM	15	TO	14			FROM	5	TO	4			FROM	11	TO	33			FROM		TO			
E	FT	80	D/R			E	FT	85	D/R			E	FT	25	D/R			E/G	FT		D/R		
	TW	80	2				TW	85	2				TW	25	1				TW				
	GV	N/A					GV	N/A					GV	N/A					GV				
	ATT	80	2				ATT	85	2				ATT	25	1				ATT				
FROM	14	TO	13			FROM	4	TO	3			FROM	7	TO	27			FROM		TO			
E	FT	80	D/R			E	FT	85	D/R			E	FT	25	D/R			E/G	FT		D/R		
	TW	80	2				TW	85	2				TW	25	1				TW				
	GV	N/A					GV	N/A					GV	N/A					GV				
	ATT	80	2				ATT	85	2				ATT	25	1				ATT				
FROM	13	TO	12			FROM	3	TO	2			FROM	7	TO	26			FROM		TO			
E	FT	80	D/R			E	FT	100	D/R			E	FT	25	D/R			E/G	FT		D/R		
	TW	80	2				TW	100	2				TW	25	1				TW				
	GV	N/A					GV	N/A					GV	N/A					GV				
	ATT	80	2				ATT	100	2				ATT	25	1				ATT				
FROM	12	TO	11			FROM	10	TO	31			FROM	6	TO	25			FROM		TO			
E	FT	82	D/R			E	FT	50	D/R			E	FT	25	D/R			E/G	FT		D/R		
	TW	82	2				TW	50	2				TW	25	1				TW				
	GV	N/A					GV	N/A					GV	N/A					GV				
	ATT	82	2				ATT	50	2				ATT	25	1				ATT				
FROM	11	TO	10			FROM	8	TO	28			FROM	5	TO	24			FROM		TO			
E	FT	120	D/R			E	FT	40	D/R			E	FT	25	D/R			E/G	FT		D/R		
	TW	120	2				TW	40	2				TW	25	1				TW				
	GV	N/A					GV	N/A					GV	N/A					GV				
	ATT	120	2				ATT	40	2				ATT	25	1				ATT				

APPENDIX D

Only Applicable to Underground Residential Distribution

Electric Trench with Joint Utilities

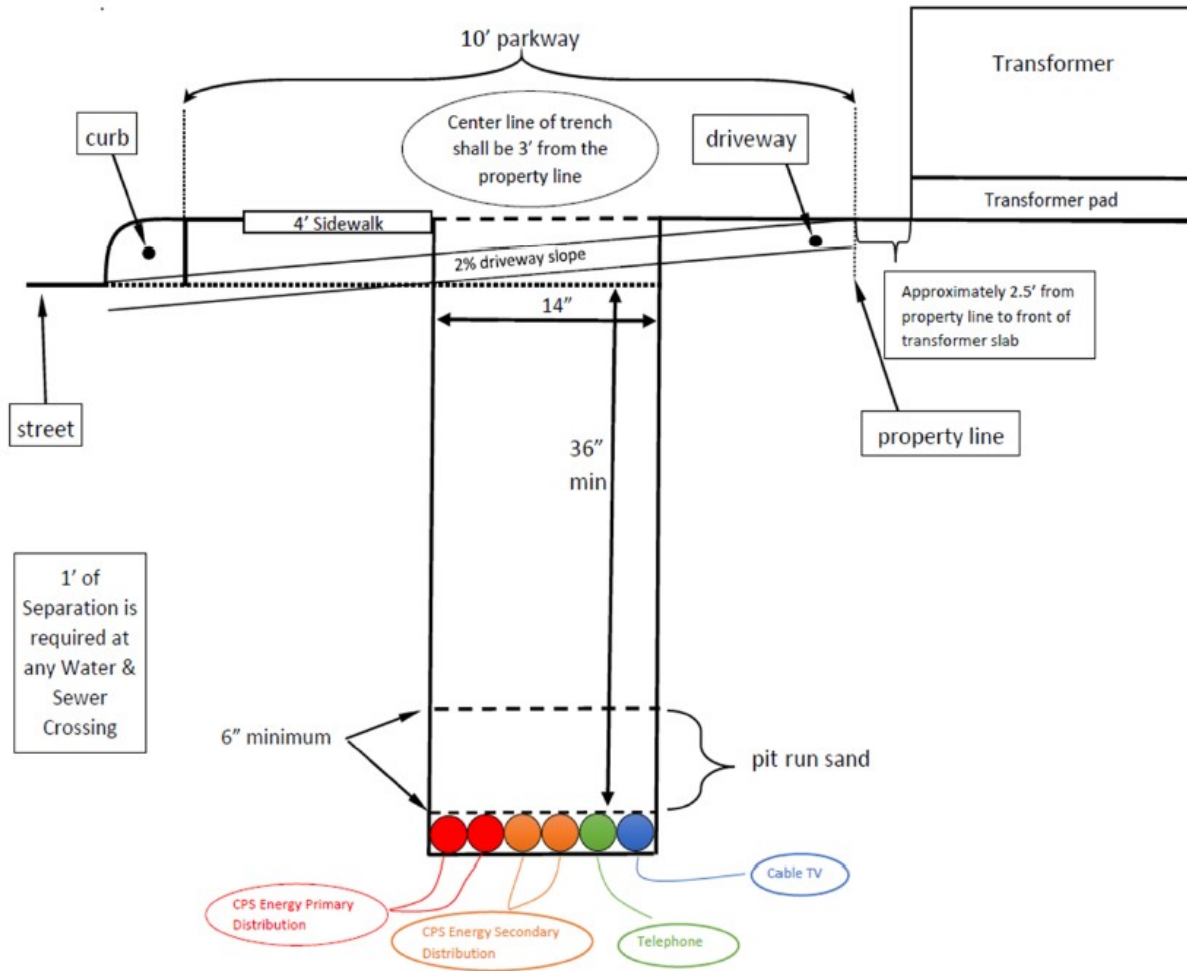

Gas & Electric Trench Joint with Other Utilities

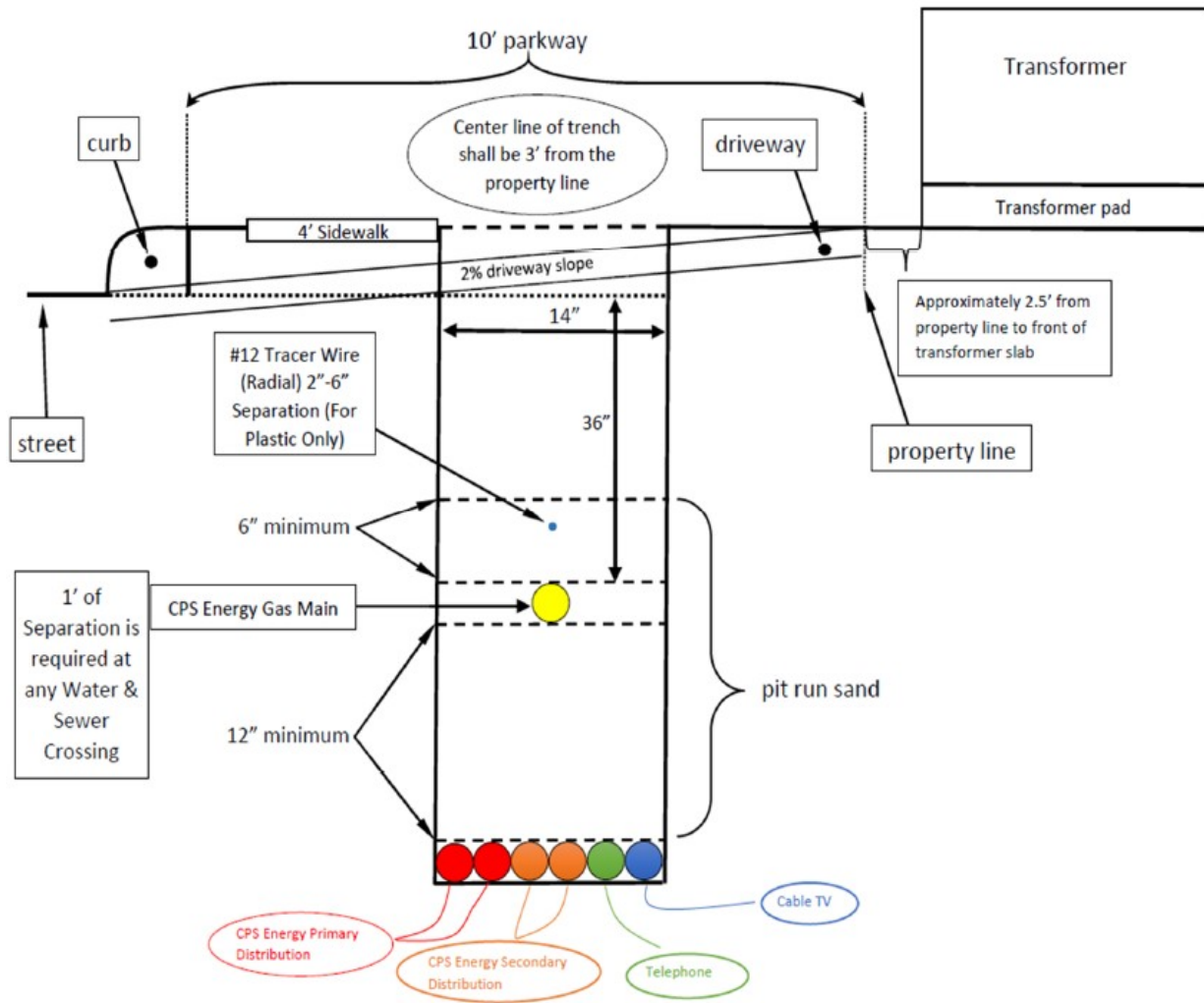

Side View Single Phase Transformer or SE6 Front Lot Construction Standard Lots with Bluffs

(Trenching in Parkway Side View Upward Slope)

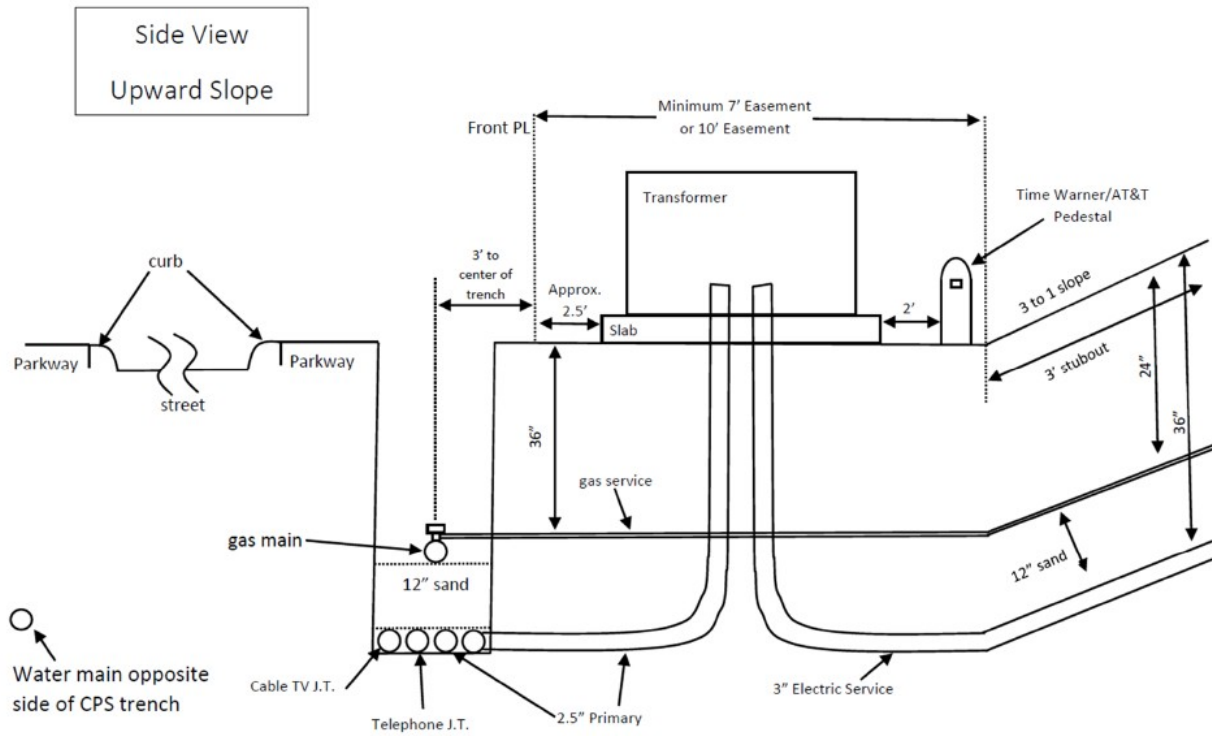

Side View Single Phase Transformer or SE6 Front Lot Construction Standard Lots with Bluffs

(Trenching in Parkway Side View Downward Slope)

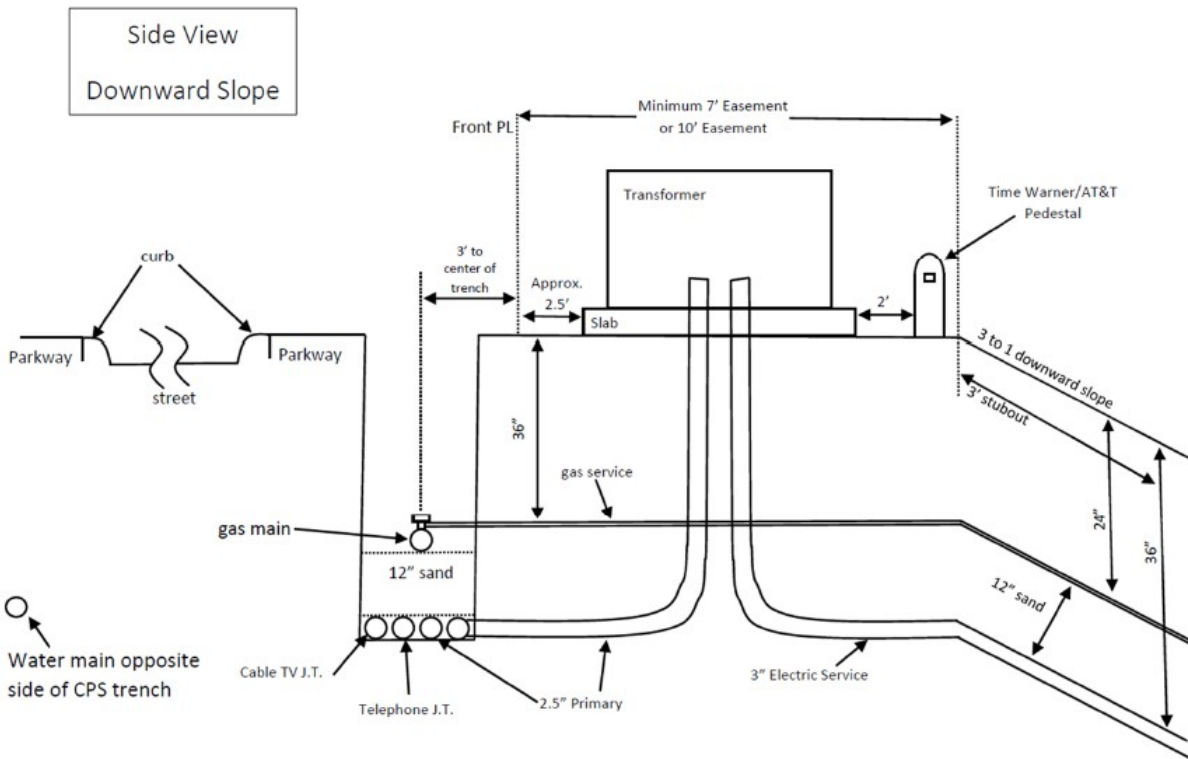



ADDENDUM A

**MINIMUM INSURANCE REQUIREMENTS
(CLASS 3)**

1. Company shall purchase and maintain in full force and effect, at its own expense, the following minimum insurance coverages and limits:

- a. Statutory Worker’s Compensation and Employer’s Liability Insurance with minimum limits of not less than indicated below. The policy must be in the name of the Company or contain an endorsement naming CPS Energy as the Alternate Employer.

Required Limits – Statutory limits, with Employer’s Liability Coverage as follows:

Bodily Injury by Accident	\$1,000,000.00
Bodily Injury by Disease Each Employee	\$1,000,000.00
Bodily Injury by Disease Policy Limit	\$1,000,000.00

- b. Commercial General Liability Insurance, including the coverages identified below, with minimum limits indicated below.

Each Occurrence	\$1,000,000.00
General Aggregate	\$2,000,000.00

The Commercial General Liability Policy will include the following coverage’s where applicable:

- i. Bodily injury & Property damage on an “Occurrence” basis
- ii. Products/Completed Operations
- iii. Premises & Operations
- iv. Independent Contractors
- v. Contractual Liability
- vi. Personal Injury Liability
- vii. Explosion, collapse, and underground exposures (XCU)

- c. Business Automobile Insurance for all owned, non-owned, and hired vehicles.

Combined Single Limit BI & PD	\$1,000,000.00
-------------------------------	----------------

- d. Excess Liability Coverage, following form, over Employers’ Liability, Commercial General Liability, Business Automobile Liability Policies, with the limits shown below.

Excess Liability Coverage	\$2,000,000.00
---------------------------	----------------

2. Each of Company’s liability insurance policies shall be **primary to and non-contributing** with, any other insurance carried by, or for the benefit of the CPS Energy. Insurance may be provided under a single limit policy, or two or more policies with combined limits for the required amount of coverage.

3. Company’s workers’ compensation, employers’ liability, business automobile liability, commercial general liability, and excess liability insurance policies shall be endorsed to waive all rights of subrogation



in favor of CPS Energy and its affiliates, and their shareholders, directors, officers, members, employees and agents.

4. CPS Energy and its employees, officers, directors, owners, advisors, consultants and agents shall be included as additional insureds without limitation on all policies (except workers' compensation), under the form of additional insured endorsement providing the maximum protection to CPS Energy allowed by applicable law. Further, Company represents and warrants that:
 - a. All such policies will be endorsed to reflect thirty (30) days' notice of cancellation to CPS Energy. Company shall not cause or permit its insurance to be canceled, reduced, restricted, limited, or invalidated.
 - b. Upon request by CPS Energy, Company shall provide true copies of the insurance policies and policy endorsements as required in this Addendum A from issuing insurance company(s).
5. All Company's insurance shall be issued by insurance carriers licensed to do business in Texas at the time the policy is issued and rated by A.M. Best Company as A-VII or better, confirmed by one or more insurance certificates listing CPS Energy's name and address as a Certificate Holder, and list the name of Project as described in this Agreement and the name and phone number of the broker who prepared the certificate. Certificates of insurance shall be prepared on an Acord form 25-S.
6. With respect to any coverage maintained on a "claims-made" policy form, Company shall maintain such coverage for two (2) years following termination of this Agreement or completion of all Services associated with this Agreement, whichever is later; provided that, if a "claims-made" policy is maintained, the retroactive date must precede the date of commencement of Services under this Agreement
7. Company shall not commence Services under this Agreement until Company has obtained all required insurance and until such insurance has been received and approved by CPS Energy. Company's failure to fulfill these insurance requirements within ten (10) days after receipt of CPS Energy's notice to proceed shall not be considered cause for any adjustment to Company's compensation or schedule. CPS Energy's approval of Company's insurance shall not relieve or decrease the liability of Company hereunder.
8. If Company fails to obtain or renew the above required insurance and furnish to the CPS Energy acceptable evidence thereof, CPS Energy shall have the right, but not the obligation, to: (1) procure such insurance and reduce the Agreement amount by the cost thereof; or (2) deem as material breach of this Agreement the Company's failure to do so.
9. Nothing herein shall reduce or alter any obligation Company has to indemnify, defend or hold harmless identified parties as provided in the Agreement.
10. In the event Company enters into a subcontract with a Subcontractor, the Company will require the Subcontractor to procure at a minimum all insurance specified to be carried by the Company, in the like form specified herein.
11. Company and, as applicable, its Subcontractors shall bear all risks and be responsible for any uninsured loss due to policy deductibles, self-insured retentions, exclusions, limitation inadequacy and/or absence of coverage, whether such policies are purchased by Company, Subcontractor and/or CPS Energy.